

Proportional Electro-hydraulic Directional Valve(BFWH)

Technical specification

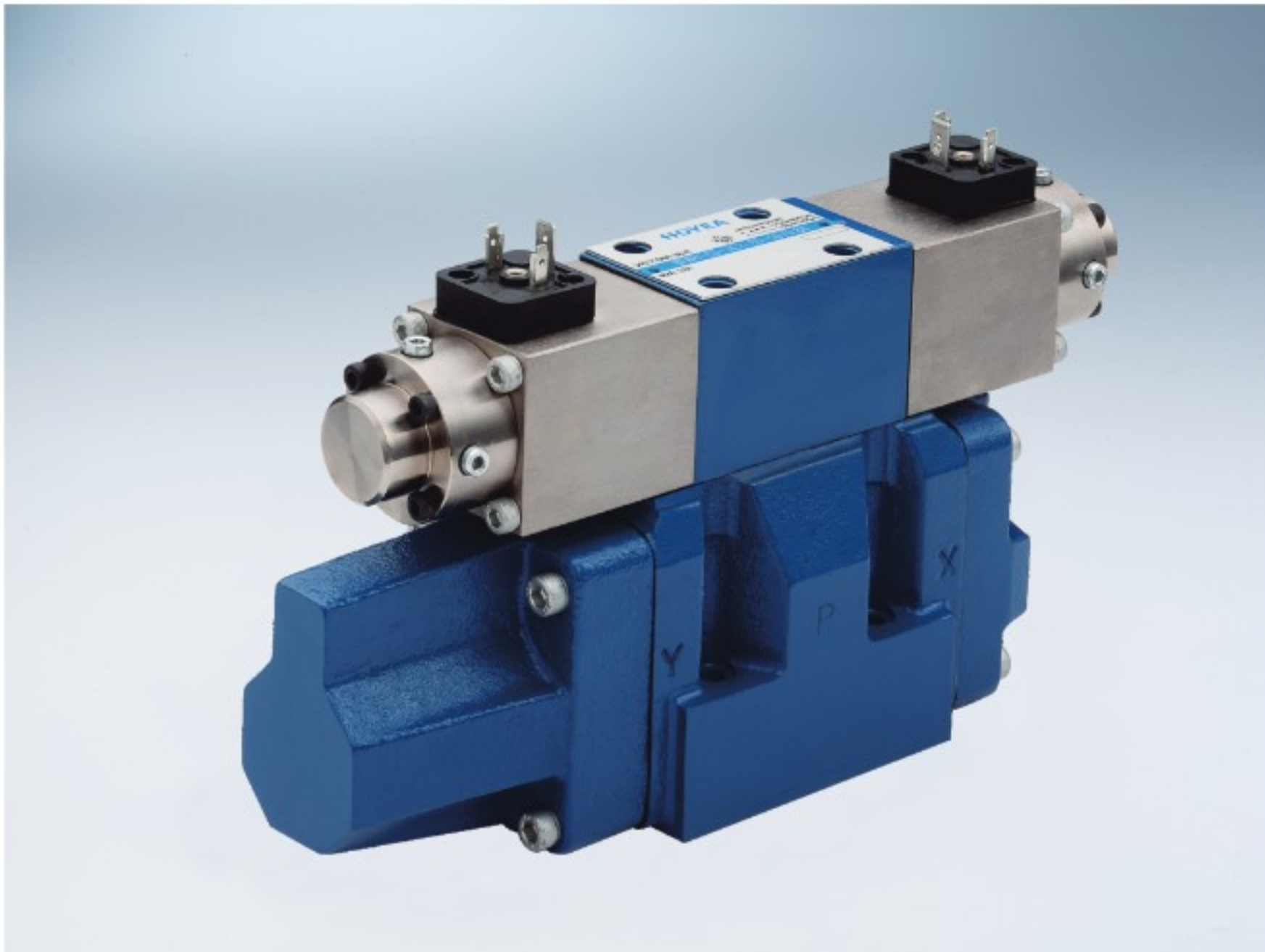

BFWH electro-hydraulic proportional directional valve is a 2-stage valve with a pilot. It is controlled by a proportional solenoid and converts the electrical signal into a fluid pressure signal to control the flow rate and directions in the hydraulic system.

Specification	03	04	06
Maximum pressure (MPa)	31.5		
Return pressure (MPa)	T(For extl disch)	< 25	
	T(For intl disch)	< 3	
	Port Y	< 3	
Maximum flow (l/min)	85	150	325
Hysteresis (%)	< 6		
Repeatability (%)	< 3		
Rated current (mA)	800		
Hydraulic fluid	Mineral oil, phosphate-ester		
Viscosity (mm ² /s)	2.8~100		
Fluid temp. (°C)	-20~70		
Coil resistance (Ω)	19.5		
Cleanliness	Filter is recommended for the highest fluid pollution degree;the lowest specific filtration resistance according to ISO 4406 (C) 20/18/15.		

Model instruction

	BFWH - * - * - * - * - 5X *	
<p>Proportional electro-hydraulic directional valve</p> <hr/> <p>Specification 03 DN 10 04 DN 16 06 DN 25</p> <hr/> <p>Symbol: (See BFW)</p> <hr/> <p>Control oil: Omit Intl cntrl intl disch X Extl cntrl intl disch Y Intl cntrl extl disch XY Extl cntrl extl disch</p>	<p>Remarks</p> <hr/> <p>Design serial number</p> <hr/> <p>Nominal flow (based on 1MPa pressure drop)</p> <p>03 Specification 25 25 l/min 50 50 l/min 85 85 l/min</p> <p>04 Specification 100 100 l/min 150 150 l/min</p> <p>06 Specification 270 270 l/min 325 325 l/min</p>	

A.3.1

Proportional Electro-hydraulic Directional Valve(BFWH)

03 Model characteristic curves (Measured at $\nu = 36 \times 10^{-6} \text{m}^2/\text{S}$ $t = 50^\circ\text{C}$)

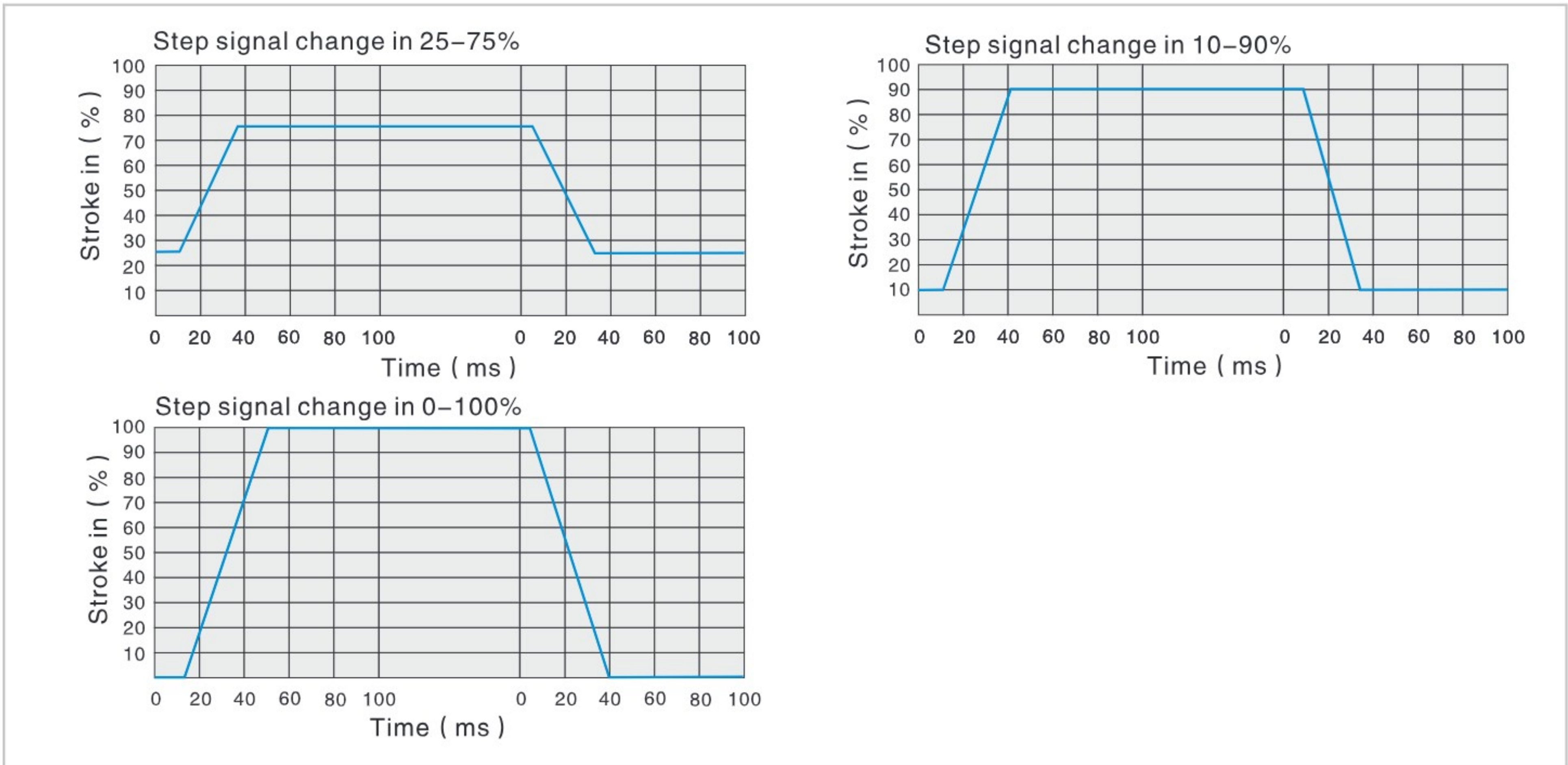

03 Model characteristic curves (Measured at $\nu = 36 \times 10^{-6} \text{m}^2/\text{S}$ $t = 50^\circ\text{C}$)

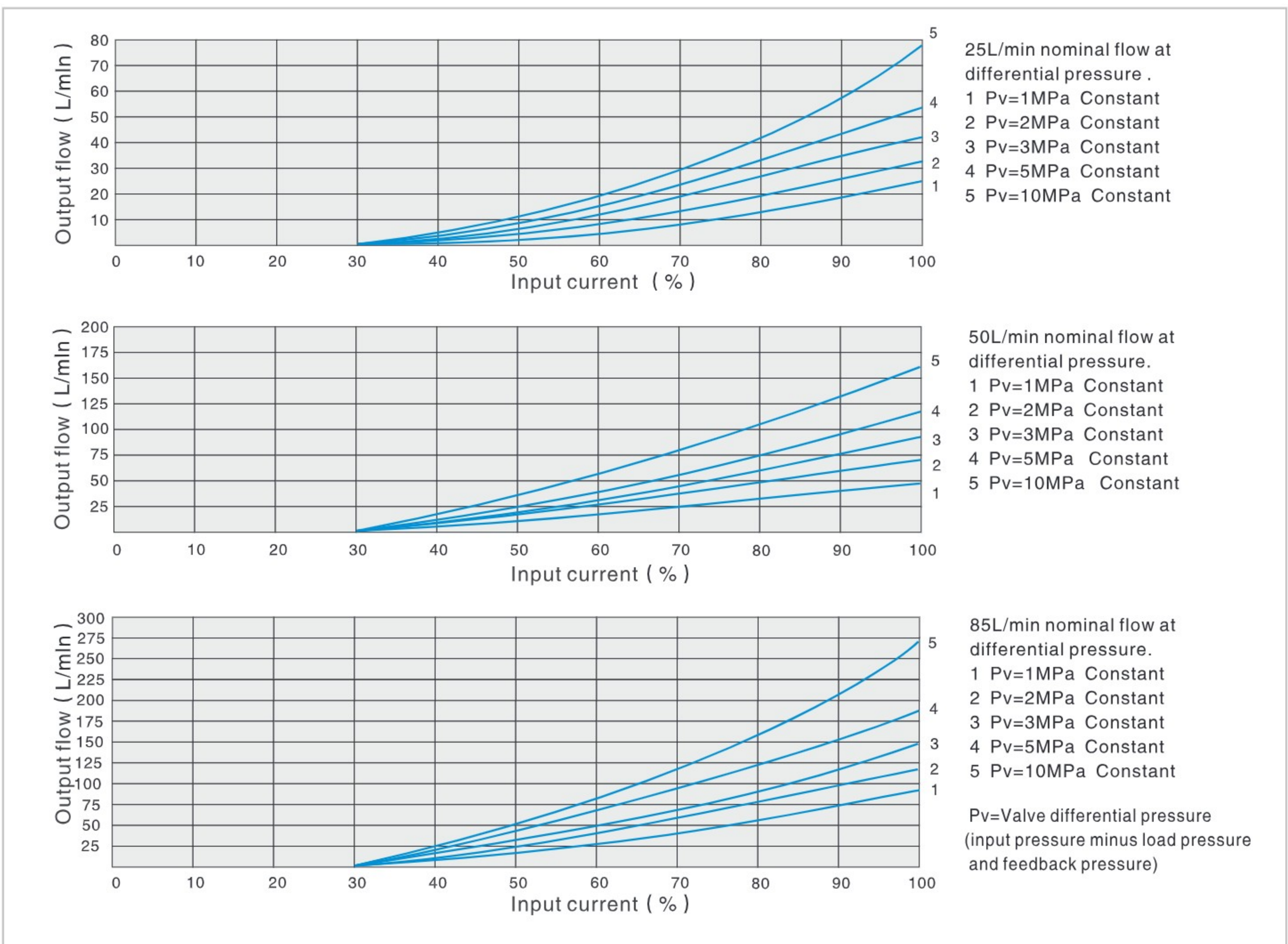

Proportional Electro-hydraulic Directional Valve(BFWH)

04 Model characteristic curves (Measured at $\nu = 36 \times 10^{-6} \text{m}^2/\text{S}$ $t = 50^\circ\text{C}$)

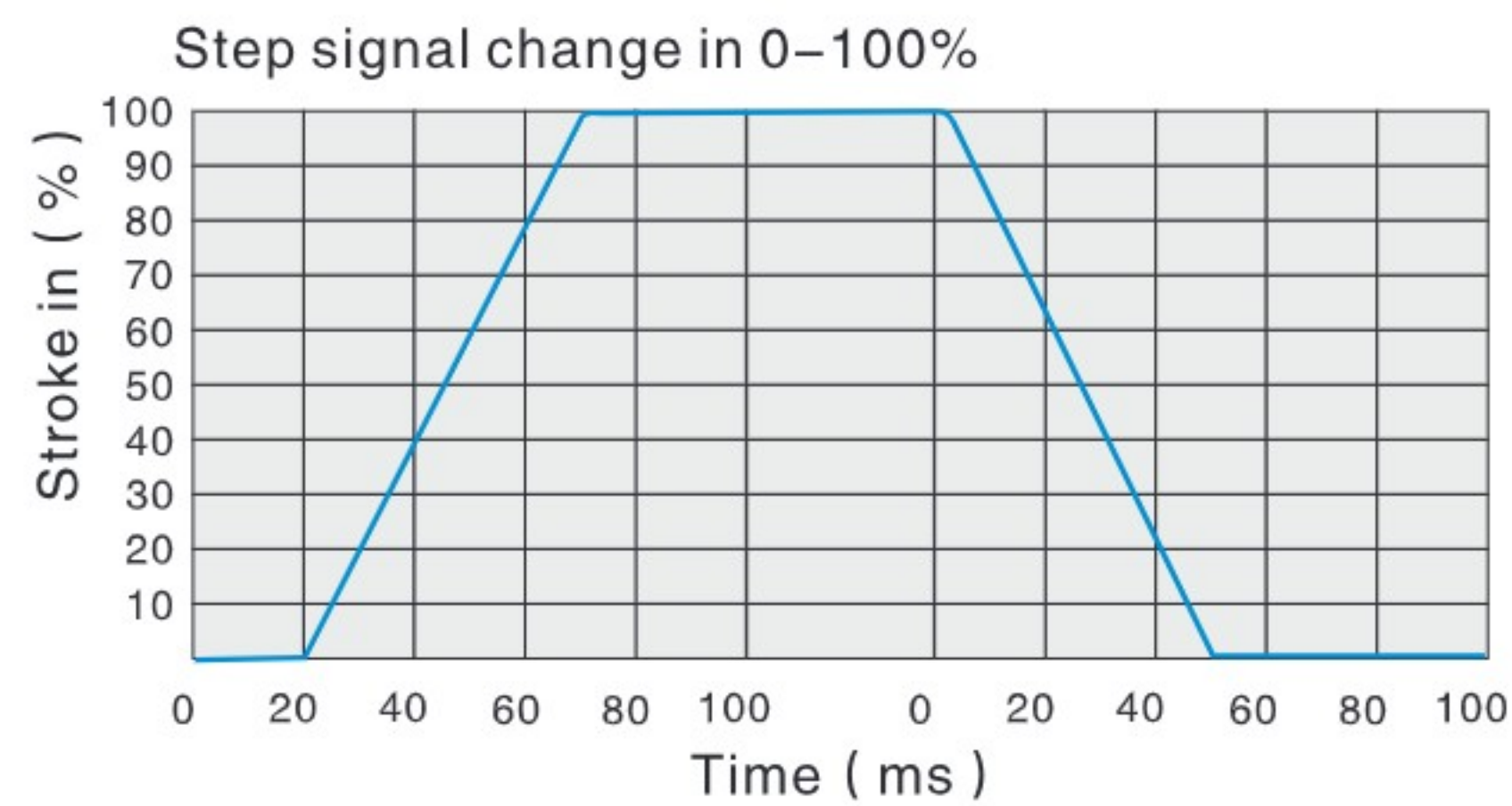
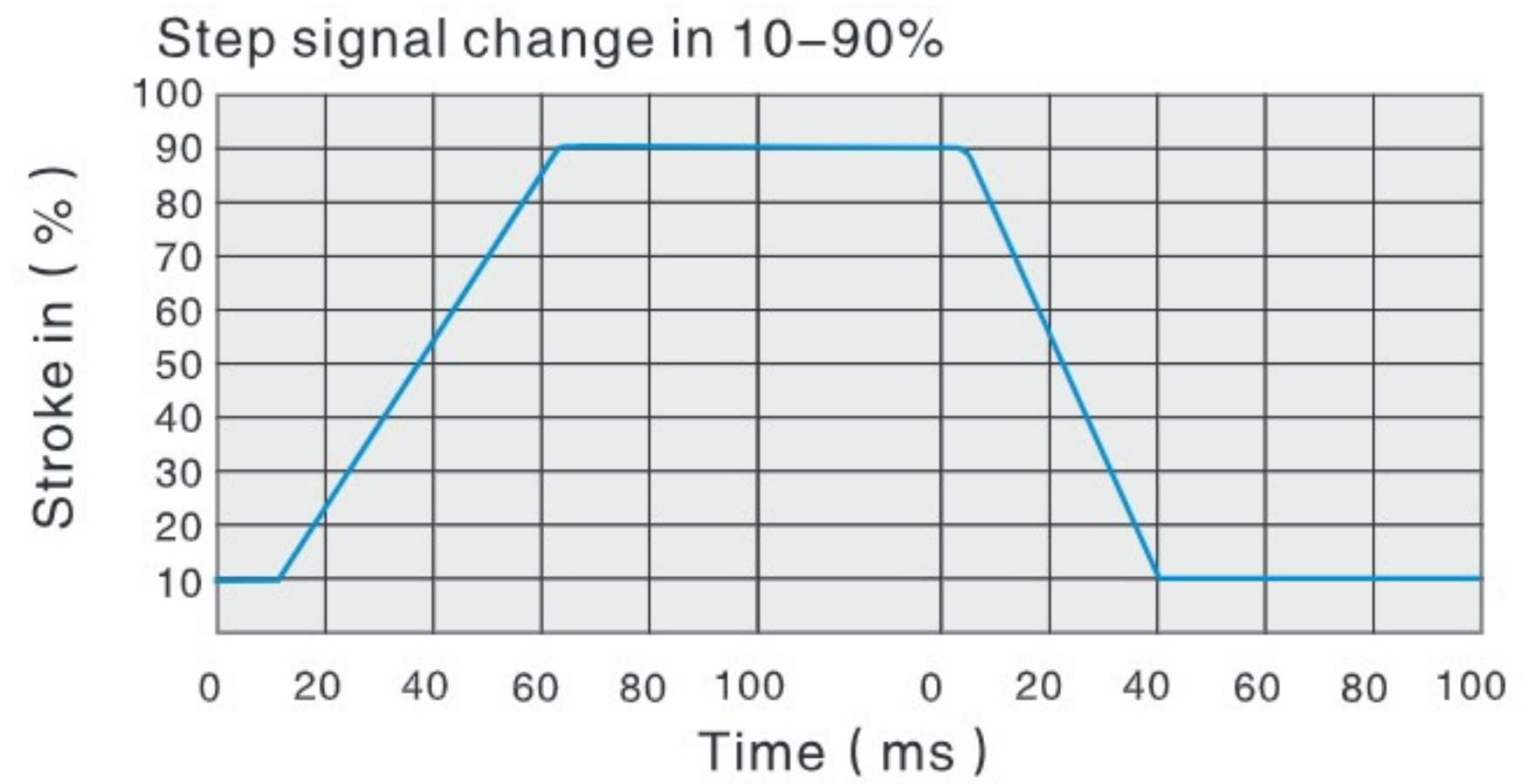
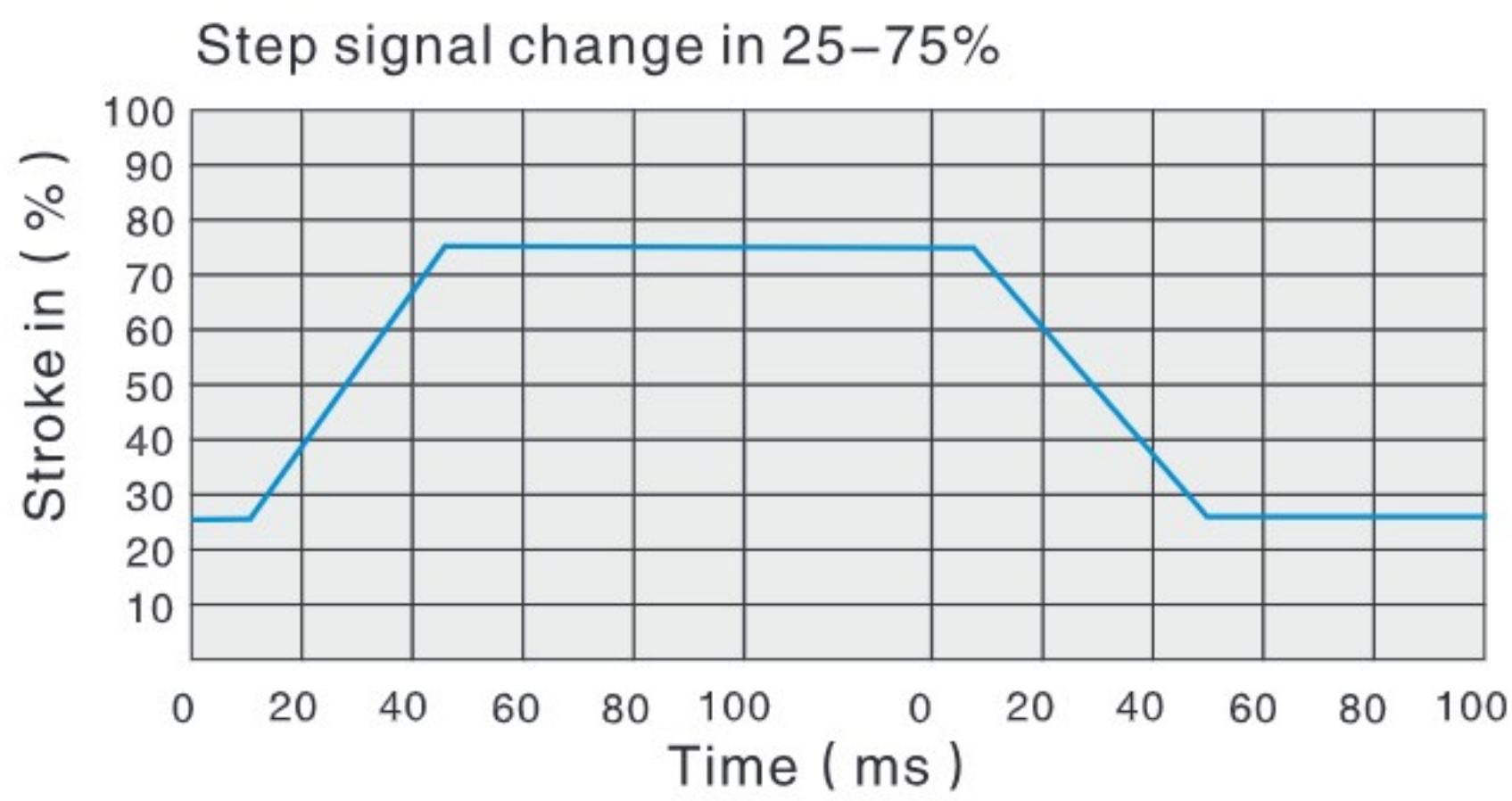

04 Model characteristic curves (Measured at $\nu = 36 \times 10^{-6} \text{m}^2/\text{S}$ $t = 50^\circ\text{C}$)

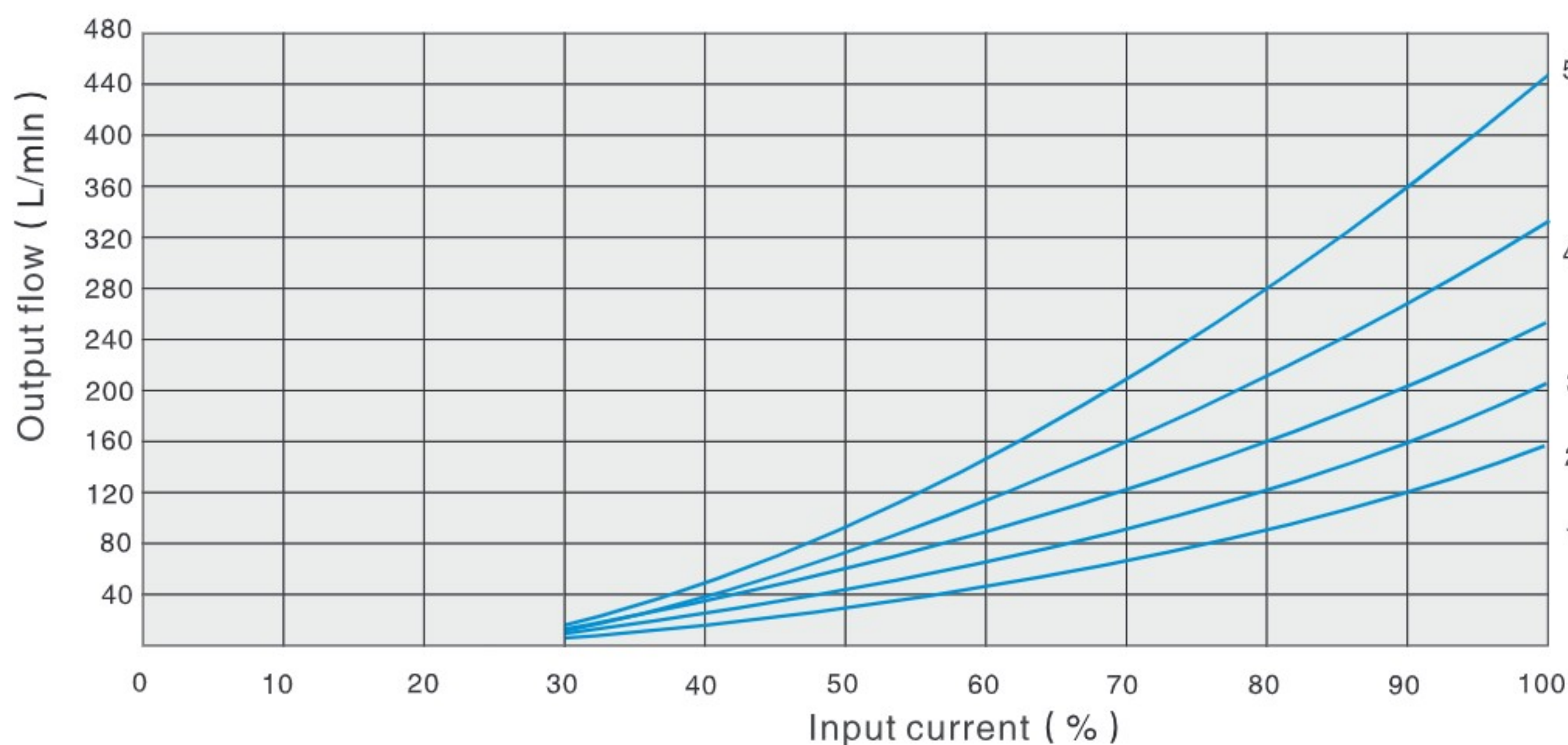
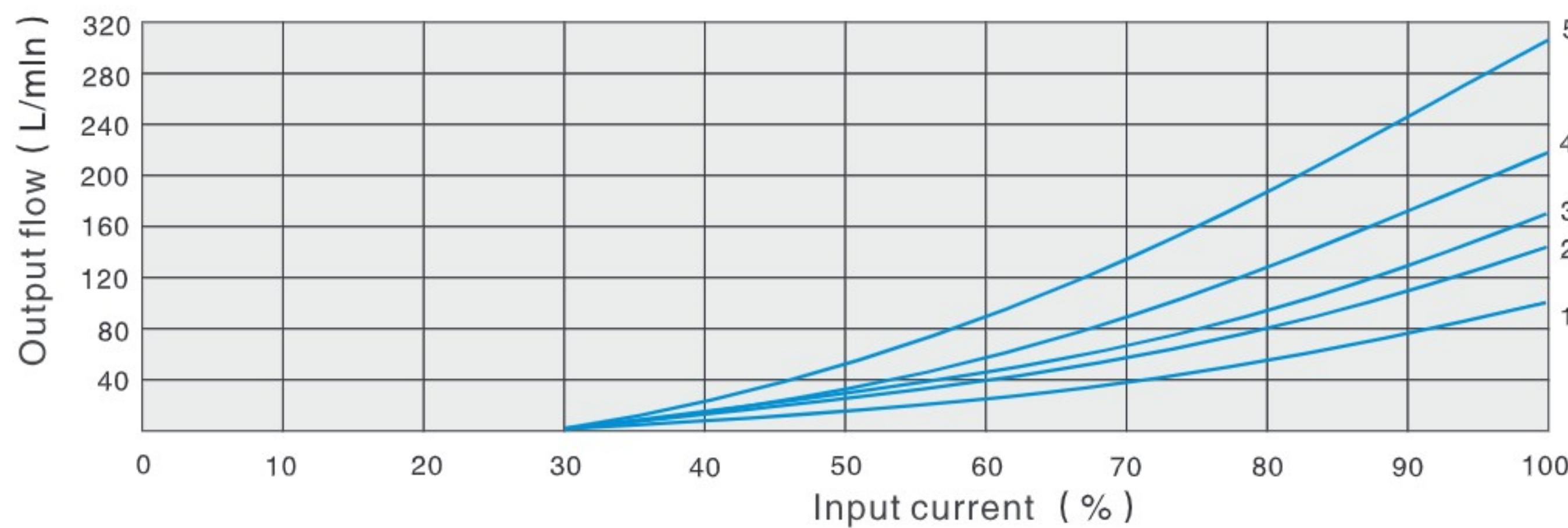

Proportional Electro-hydraulic Directional Valve(BFWH)

06 Model characteristic curves (Measured at $\nu=36 \times 10^{-6} \text{m}^2/\text{S}$ $t=50^\circ\text{C}$)

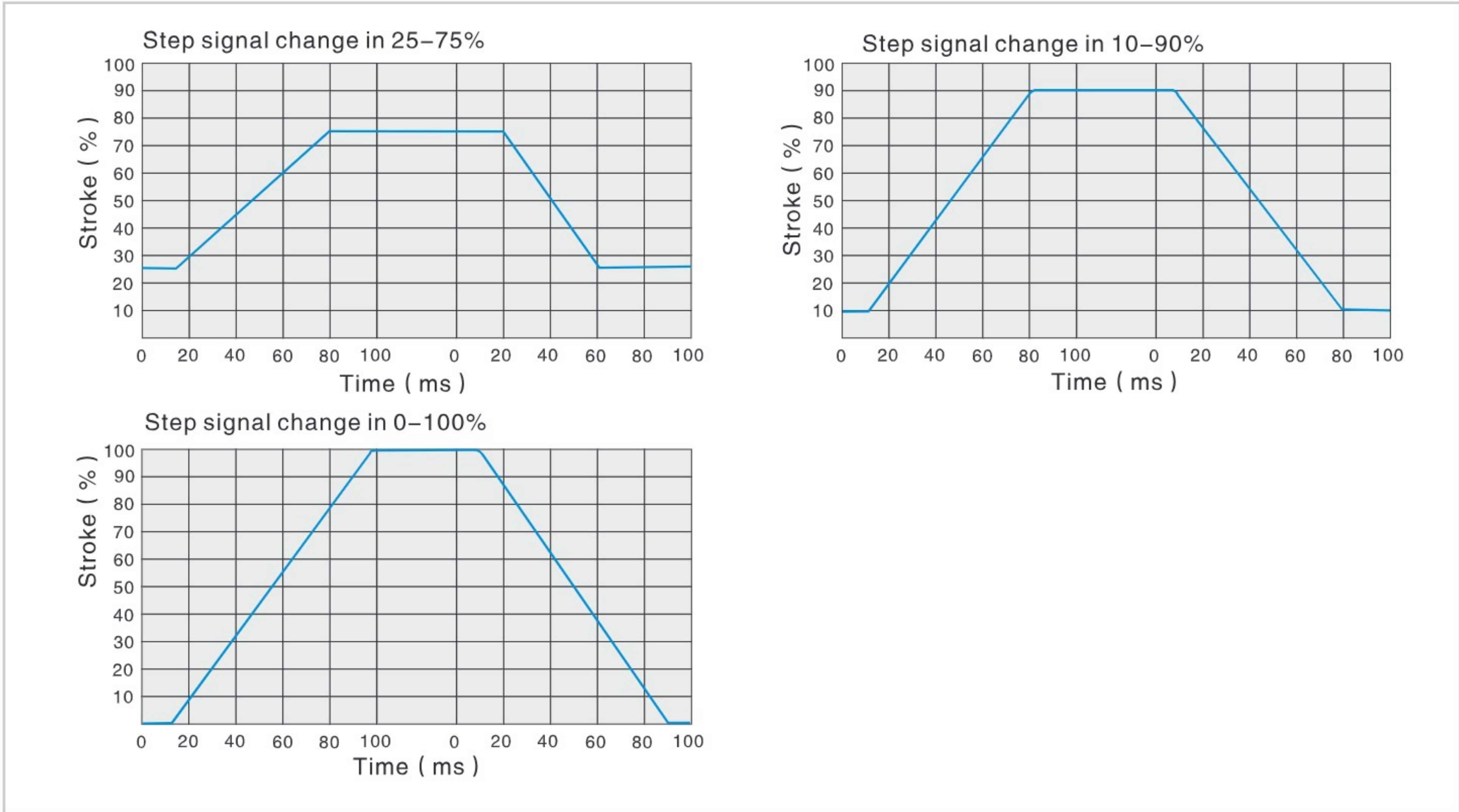

A.3.4

06 Model characteristic curves (Measured at $\nu=36 \times 10^{-6} \text{m}^2/\text{S}$ $t=50^\circ\text{C}$)

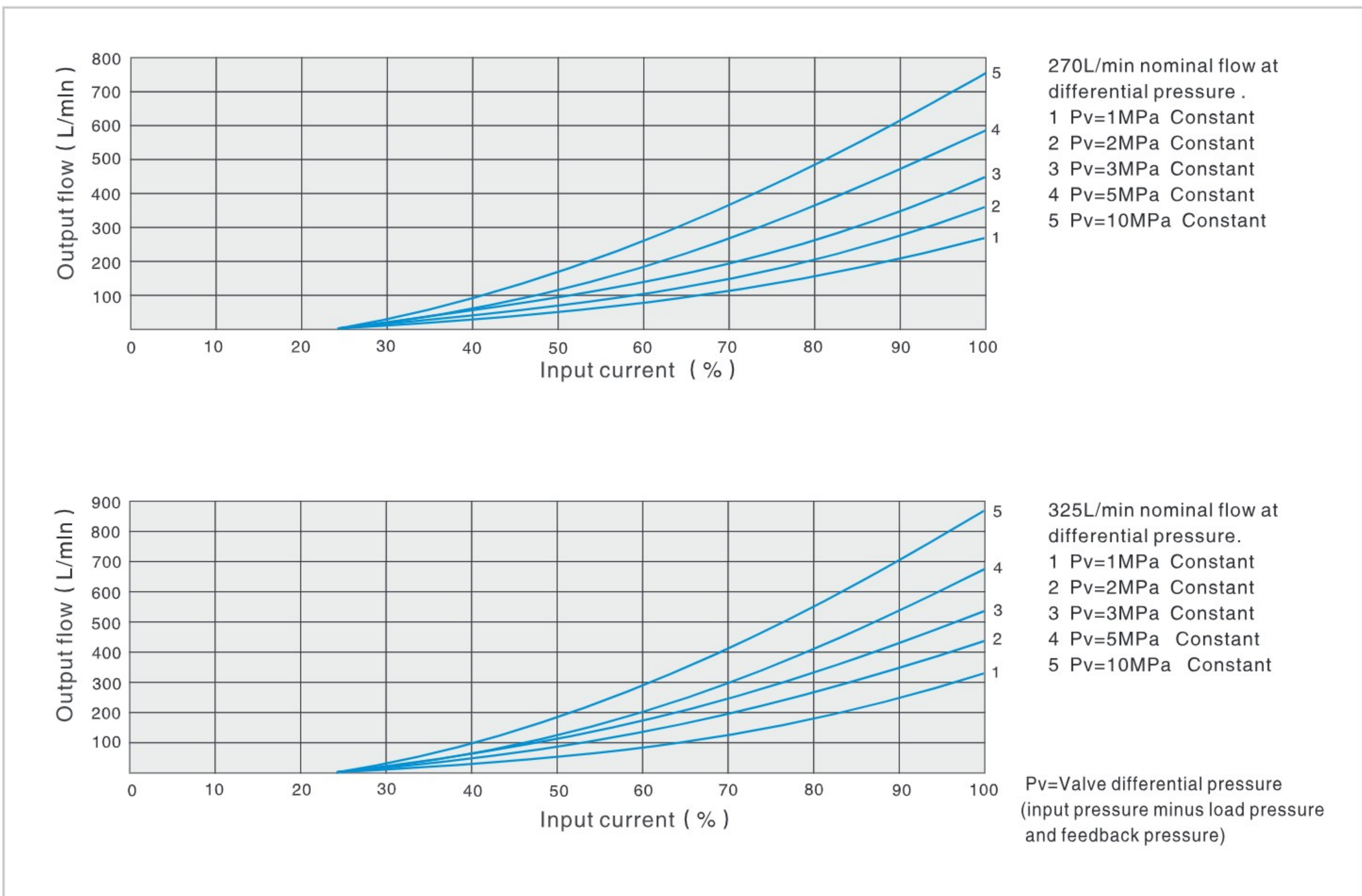

Proportional Electro-hydraulic Directional Valve(BFWH)

External dimensions

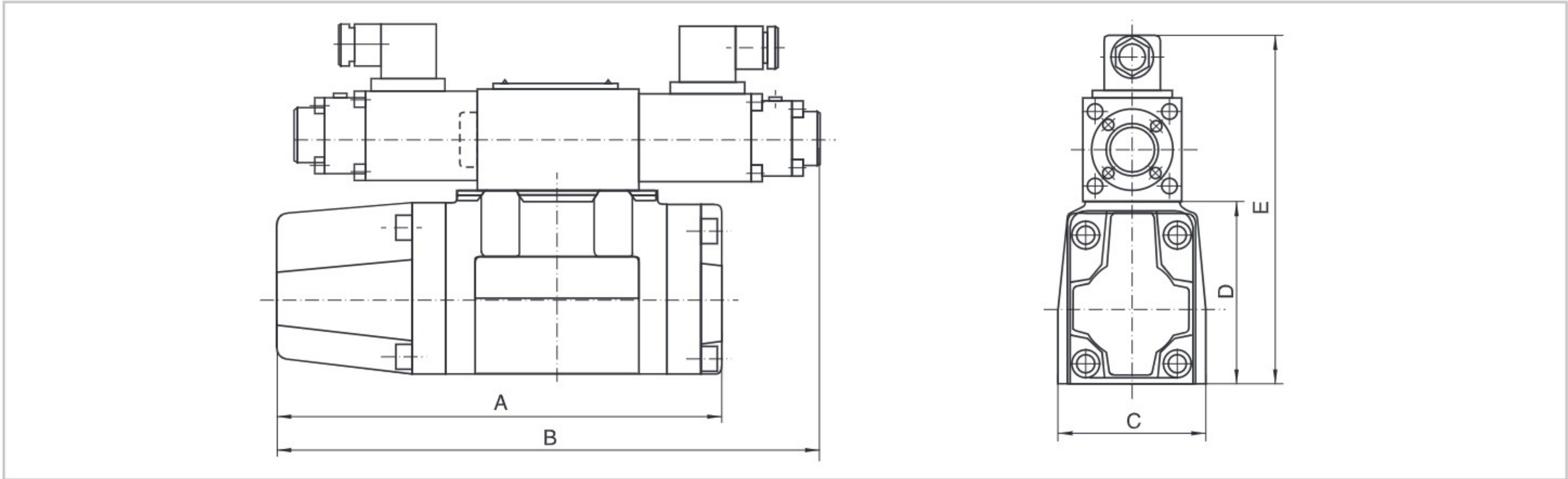

Specification	A	B	C	D	E
BFWH-03	216	250	70	86	171
BFWH-04	250	265	94	95	185
BFWH-06	280	290	120	117.5	202.5

Plate size

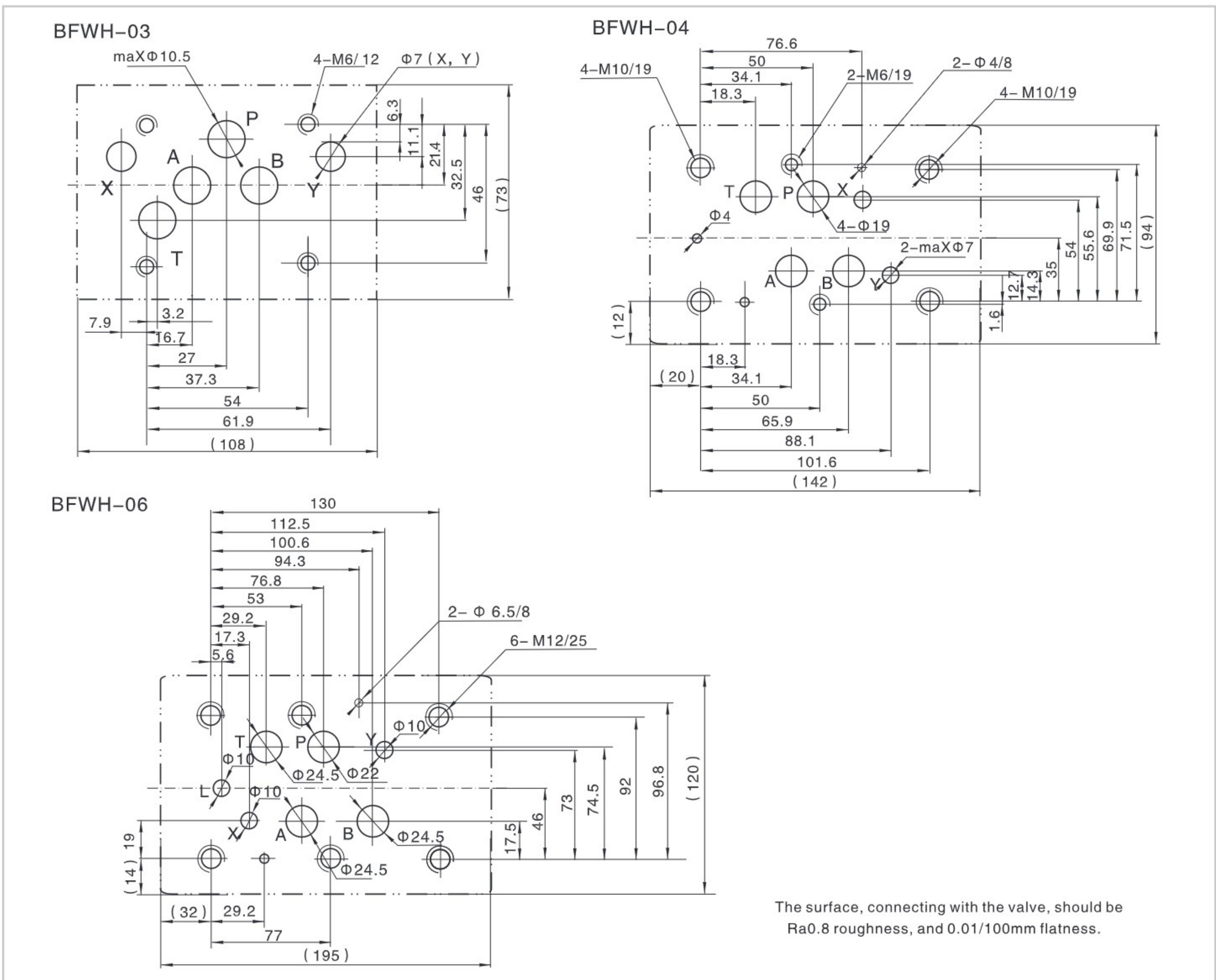

The surface, connecting with the valve, should be Ra0.8 roughness, and 0.01/100mm flatness.