

“BT/BG” Series Pilot Operated Relief Valves



RV series pilot operated relief valves can be used to control and unload system pressure.

Ordering details

B	G	03	1	30
Sort	Mounting type	Nominal size	Pressure adjustment range	Design code
Pilot operated relief valves	G:Subplate mounting T:Thread mounting	03:NG10 06:NG20 04:PT1/2" 06:PT3/4"	1:8~70bar 2:35~140bar 3:70~250bar	30

Technical specification

Model	BG-03	BG-06	BT-03	BT-06
Max. flow rate (l/min)	100	200	100	200
Working pressure (MPa)	25			
Weight(kgs)	5.6	6.9	2.8	4.5

Symbol

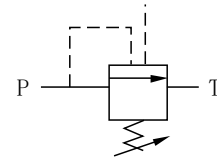

Dimensions

Unit: mm

BT-03/06

Model	A	B	C	D	P	T
BT-04- **	MAX. 142	92	111	84.5	PT1/2"	PT1/2"
BT-06- **	MAX. 148	102	140	103	PT3/4"	PT3/4"

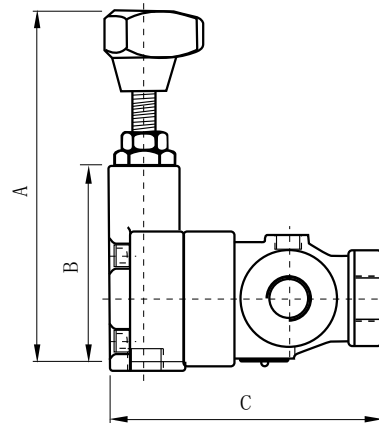
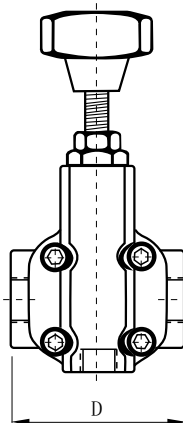
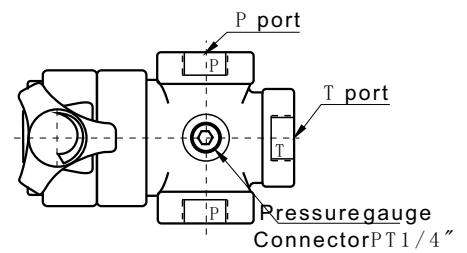

Dimensions

Unit: mm

BG-03/06

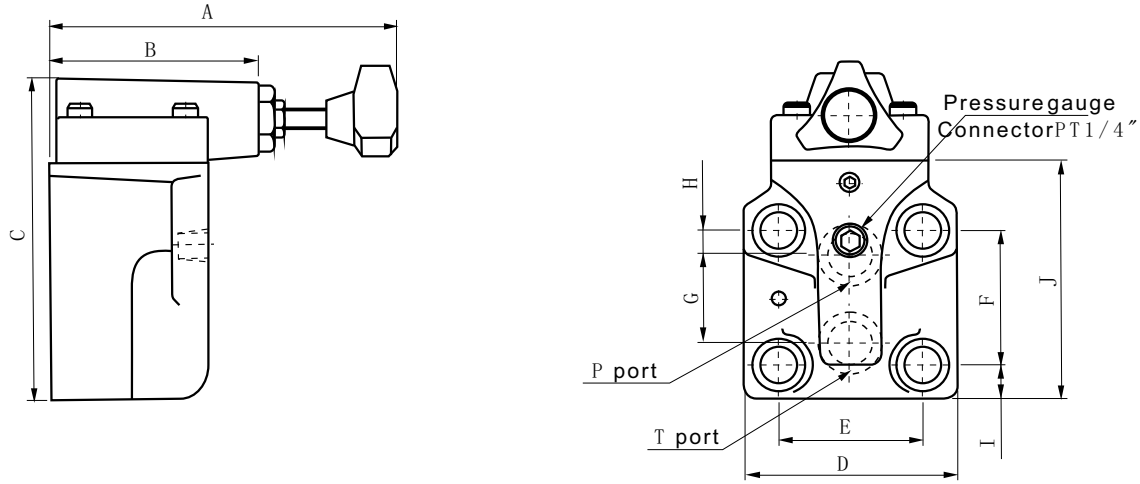

Model	A	B	C	D	E	F	G	H	I	J
BG-03- **	MAX. 165	104	140	84	54	54	25	22	22.5	100
BG-06- **	MAX. 175	104	160	105	70	66.6	44.1	11.1	16.9	122

Mounting size

BG-03

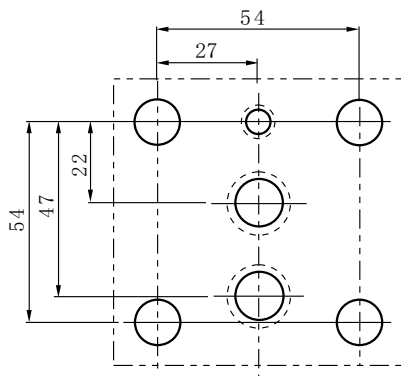

BG-06

