

# “DB” Series Pilot Operated Relief Valves

# “DBW” Series Solenoid Pilot Operated Relief Valves

DB series pilot operated relief valves and DBW series solenoid operated relief valves can be used to control and unload system pressure.

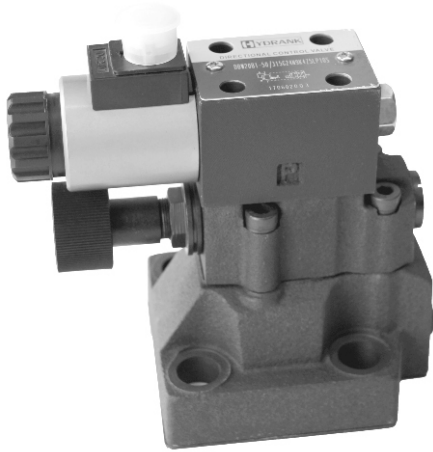

## Technical specification

Model		DB-10	DB-20	DB-30
Max. flow rate (l/min)	Subplate mounting	250	500	650
	Threaded mounting	250	500	650
Working pressure (MPa)	50 series	35		
Weight(kgs)	Subplate mounting	2.6	3.5	4.4
	Threaded mounting	5.3	5.1	4.8
	Pilot solenoid valve	1.2		

## Ordering details

DB	W	C	10		A	G	1
Sort	With solenoid valve	Pilot valve	Nominal size		Normal state	Mounting type	Adjustment type
Pilot operated relief valve	No code: Without solenoid valve W: With solenoid valve	No code: Complete DB valve C: Pilot operated valve without main spool C: Pilot operated valve with main spool (enter size 10~30) T: Pilot operated valve for remoted control valve	Subplate mounting 10: NG10 20: NG20 30: NG30	Threaded mounting 10: G1/2" M22×1.5 20: G1" M33×2 30: G1 1/2" M48×2	A: Normal closed B: Normal open	No code: Subplate mounting G: Threaded mounting	1: Rotary knob 2: Sleeve with hexagon and protective cap 3: Lockable rotary knob with scale 7: Rotary knob with scale

50	50	XY	U	G24	N	Z4L	V
Series number	Setting pressure	Oil control	Cracking pressure	Input voltage	Manual override	Connector type	Seals
50:50 series	50: 5MPa 100: 10MPa 200: 20MPa 315: 31.5MPa 350: 35MPa	See oil control list	No code: 0.5MPa U: 0.25MPa	G24: DC24 W220: AC220	No code: Without manual override N: With manual override	Z4: Standart plug-in connector Z4L: Plug-in connector with light	No code: NBR seals for petroleum oils V: FPM seals for phosphate ester

## Symbol list

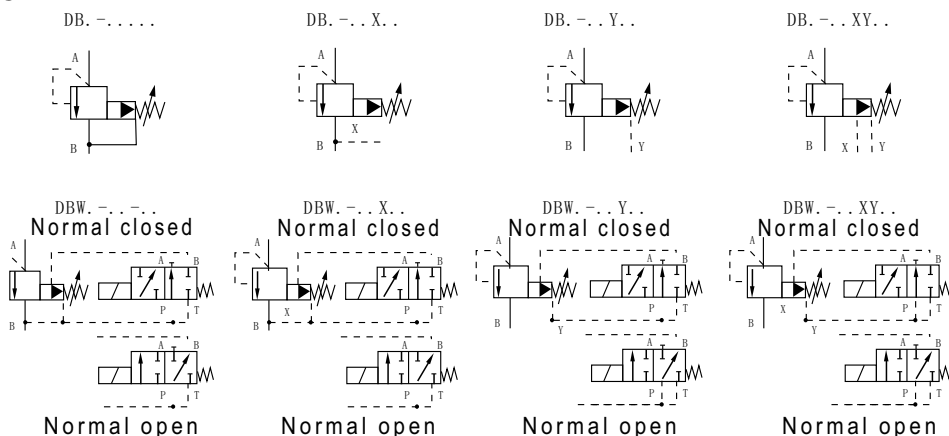

No code	Internal control internal drain
X	External control internal drain
Y	Internal control external drain
XY	External control external drain

### Dimensions

Unit: mm

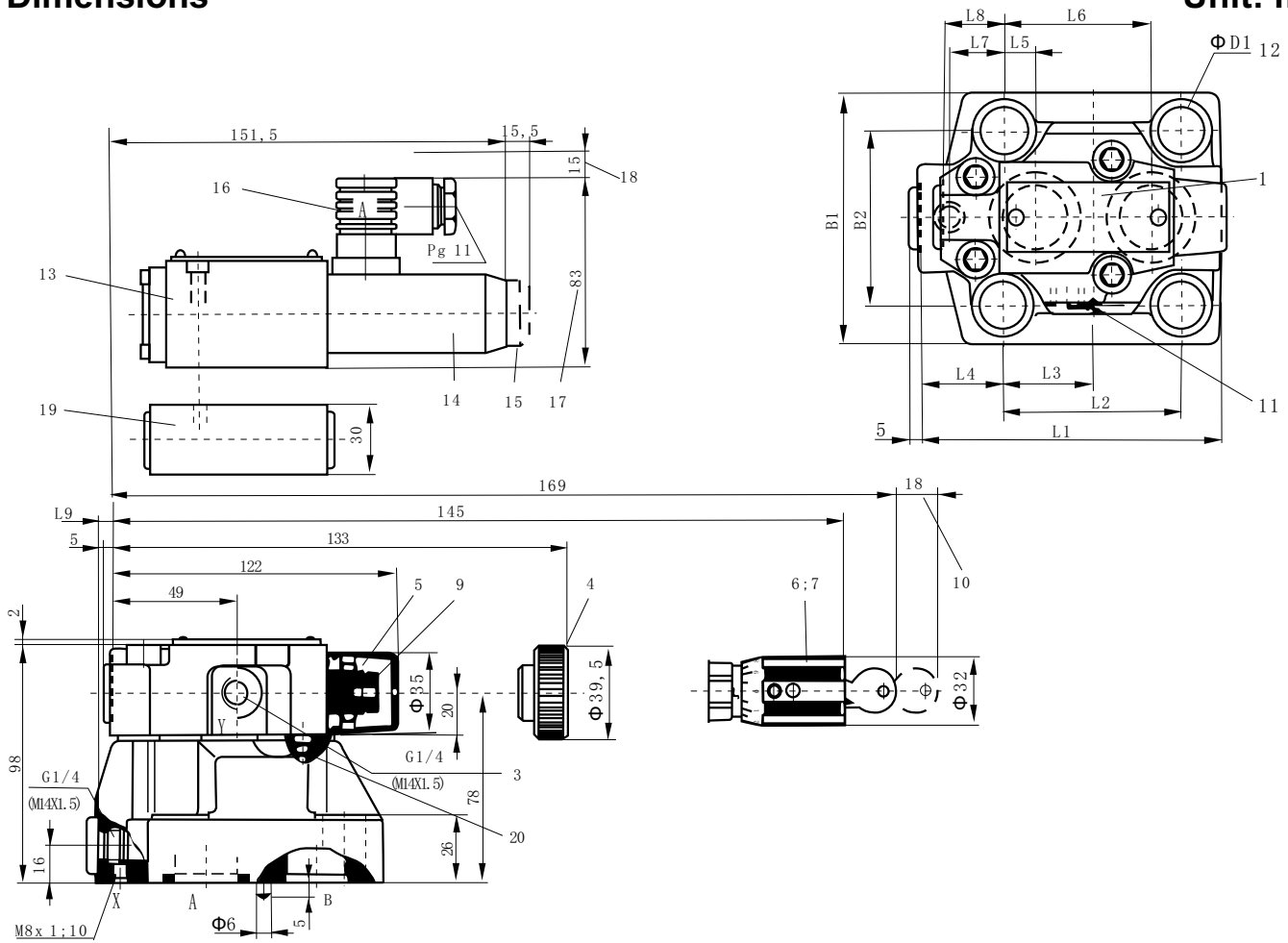

Model	L1	L2	L3	L4	L5	L6	L7	L8	L9	B1	B2	D1	O-rings A, B port	O-rings X port
DB/DBW 10	91	53,8	22,1	27,5	22,1	47,5	0	25,5	2	78	53,8	14	17.12X2.62	9.25X1.78
DB/DBW 20	116	66,7	33,4	33,3	11,1	55,6	23,8	22,8	10,5	100	70	18	28.17X3.53	9.25X1.78
DB/DBW 30	147,5	88,9	44,5	41	12,7	76,2	31,8	20	21	115	82,6	20	34.52X3.53	9.25X1.78

### Mounting size

Unit: mm

DB/DBW-10

DB/DBW-20

DB/DBW-30

