

**VARAK**  
HYDRAULICS

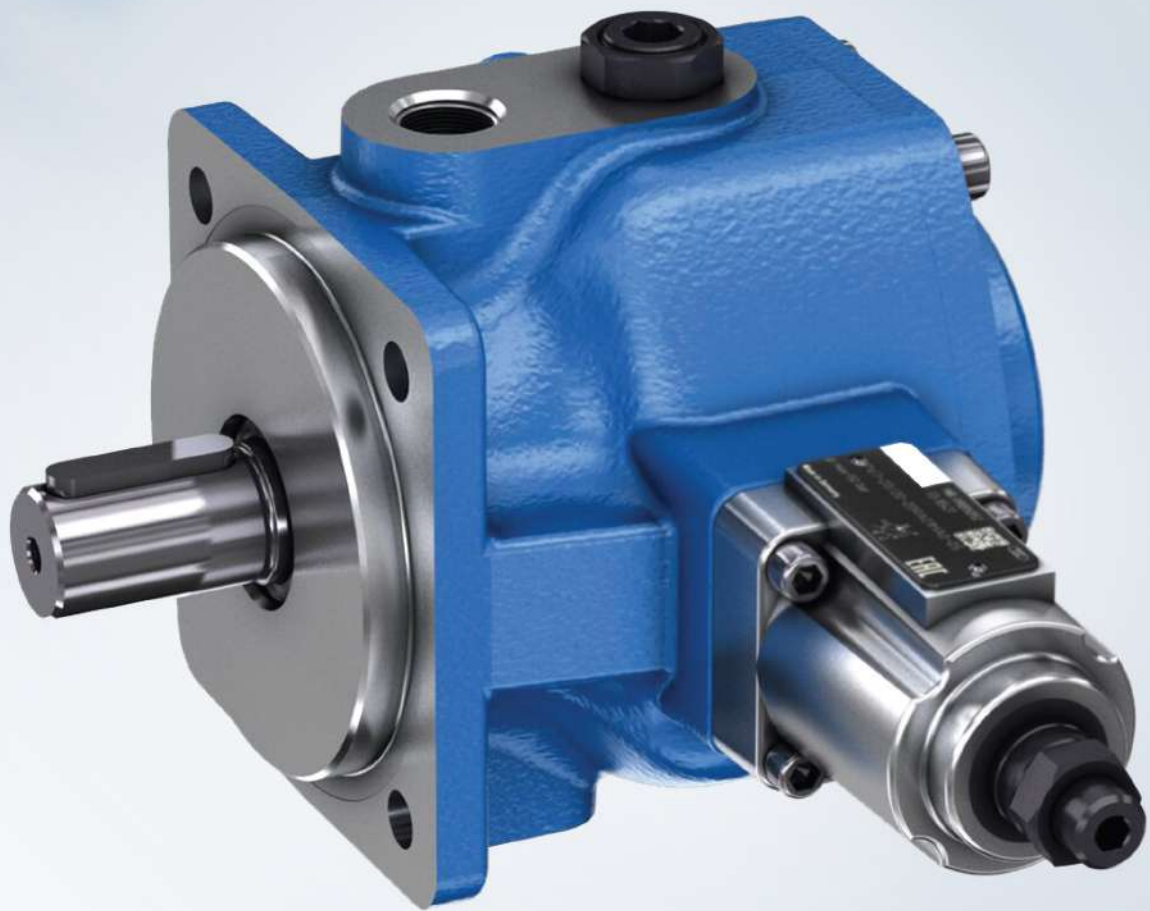

**VANE PUMP PV7-1X/06-10RA01MA0-10**



**HI-TECH HYDRAULICS**

DETAIL CATALOGUE

## Variable Vane Pump, Direct Controlled PV7...A Series 1X



- ▶ Sizes 10
- ▶ Maximum pressure 100 bar
- ▶ Displacement volume 10 cm<sup>3</sup>

### Features

- ▶ Very short control times
- ▶ Low noise
- ▶ Mounting and connection dimensions to VDMA 24560/1 and ISO 3019-2
- ▶ Good efficiency
- ▶ Long service life
- ▶ Variable displacement volumes

### Ordering code

01	02	03	04	05	06	07	08	09	10	11
PV7	-	/	R	A	01	M	A	-		

#### Type

01	Vane pump, direct controlled, maximum operating pressure 100 bar	<b>PV7</b>
----	--	------------

#### Series of devices

02	Frame size 06, device series 10 to 19, unchanged mounting and connection dimensions	<b>1X</b>
----	---	-----------

#### Frame size BG

#### Size NG [cm<sup>3</sup>]

03	BG 06	10	<b>06-10</b>
----	-------	----	--------------

#### Direction of rotation

04	Viewed on drive shaft, right	<b>R</b>
----	------------------------------	----------

#### Drive shaft

05	Parallel keyed shaft	<b>A</b>
----	----------------------	----------

#### Pipe connections

06	Suction and pressure port with pipe thread according to DIN EN ISO 228-1	<b>01</b>
----	--	-----------

#### Seals

07	NBR seals, suitable for HLP mineral oil according to DIN 51524	<b>M</b>
----	--	----------

#### Control unit

08	Direct controlled	<b>A</b>
----	-------------------	----------

#### Control device

09	Adjustment screw (Standard)	<b>0</b>
----	-----------------------------	----------

#### Zero stroke pressure range<sup>1)</sup>

10	V7/06-10	50 to 100 bar	<b>10</b>
----	----------	---------------	-----------

## Functional description

Hydraulic pumps, type PV7...A are direct controlled vane pumps with variable displacement.

The basically comprise of the housing (1), cover (2), rotor (3), vanes (4), stator ring (5), pressure spring (6), adjustment screw (7) and control plate (8).

For limiting the maximum flow, the pump is fitted with an adjustment screw (9).

The driven rotor (3) rotates within the stator ring (5). The vanes (4) which are guided in the rotor (3) are pressed against the inner running surface of the stator ring (5) by centrifugal force.

### Suction and displacement process

The chambers (10) which are required for the transport of the hydraulic fluid are formed by the vanes (4), the rotor (3), the stator ring (5), the control plate (8) and the cover plate (2).

The chamber volume increases as the rotor (3) rotates and the chambers are filled with hydraulic fluid via the suction channel (S). When the largest chamber volume is reached, the chambers (10) are separated from the suction side. As the rotor (3) continues to rotate the connection to the pressure side is opened, the chambers decrease in size and force the hydraulic fluid into the system via the pressure port (P).

### Pressure control

The stator ring (5) is held in its initial excentric position by spring (6). The maximum operating pressure required in the system is set at the adjustment screw (7) via the spring (6).

The pressure which builds up due to the work resistance acts on the pressure side of the inner running surface of the stator ring (5), against the force of the spring (6). When the relevant pressure is reached, which is determined by the set spring force, the stator ring (5) is moved out of its excentric position in the direction of the zero position. The flow adjusts itself to the value which is being demanded at that time. When the maximum pressure, which has been set at the spring (6), has been reached then the pump regulates the flow back to virtually zero. The operating pressure is maintained and only the case drain is replaced. Losses and heating of the hydraulic fluid is thereby minimized.

### ▼ PV7-1X/06...A...

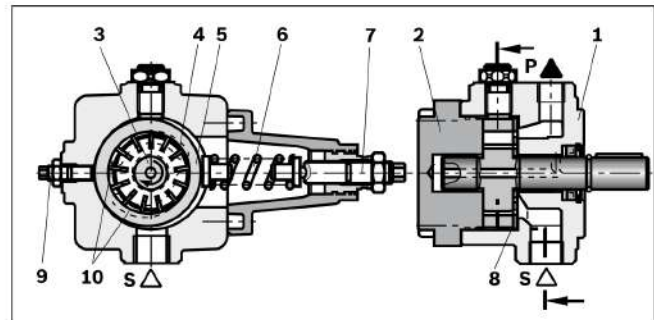

### ▼ Symbol

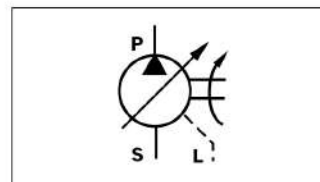

## Technical data

Frame size		BS	06
Displacement	$V$	cm <sup>3</sup>	10
Speed	$n$	rpm	900 to 1800
Torque maximum	$T$	Nm	50
Operating pressure, absolute	Inlet	$p_{\text{min-max}}$	bar 0.8 to 2.5
	Outlet	$p_{\text{max}}$	bar 100
	Case drain outlet	$p_{\text{max}}$	bar 2
Case drain flow at zero stroke (at outlet operating pressure= $p_{\text{zero stroke max}}$ )	$q_v$	l/min	1.7
Shaft loading		Radial and axial forces are not permissible	
Flow maximum <sup>1)</sup> (at $n = 1450$ rpm $p = 10$ bar; $v = 41$ mm <sup>2</sup> /s)	$q_v$	l/min	14.5
Weight	$m$	kg	6.3
Flow change (at one revolution of the adjustment screw and $n = 1450$ rpm)	$q_v$	l/min	7.5
Hydraulic fluid		Mineral oil HLP according to DIN 51524 part 2 Please take the specifications stated in data sheet 90220 into account! Further fluids on request.	
Hydraulic fluid temperature range	$\theta$	°C	-10 to +70, take the permissible viscosity range into account!
Viscosity range	$v$	mm <sup>2</sup> /s	16 to 160 at operating temperature maximum 800 at pump start with an operating flow maximum 200 at pump start in zero flow condition
Maximum permissible degree of contamination of the hydraulic fluid, cleanliness level according to ISO 4406 (c)		Class 19/16/13 <sup>2)</sup>	
Mounting style		Flange mounting	

### Dynamic characteristics measuring layout

The control times are valid for the measurement build-up as shown. For other set-ups and line lengths the control times will change.

▼ Schematic

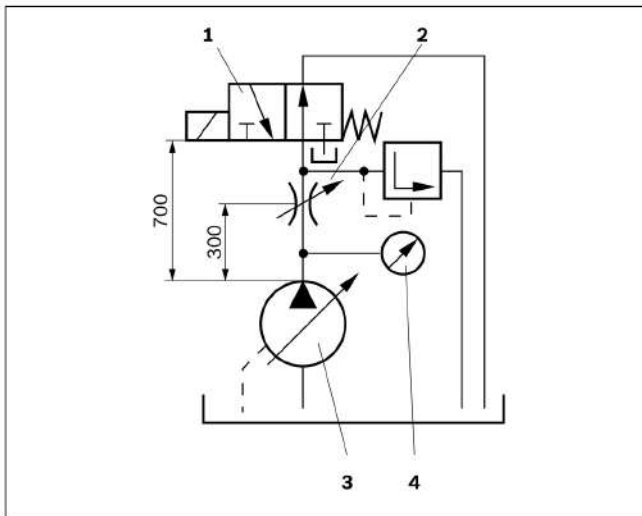

- 1 Directional valve (switching time 30 ms)
- 2 Throttle for setting the pressure during displacement
- 3 Hydraulic pump
- 4 Pressure measuring point

### Control down

$q_v$  displacement →  $q_v$  zero stroke

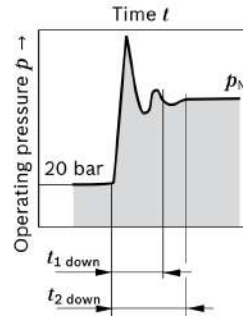

Pump type	Pressure		Control times (median values)	
	$p_N$ [bar]	$p_{max}^{1)}$	$t_{1\ down}$	$t_{2\ down}$
06-10...10	100	150	85	90

### Control up

$q_v$  zero stroke →  $q_v$  displacement

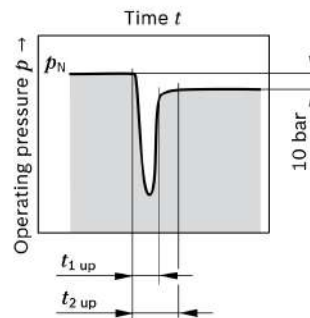

Pump type	Pressure	Control times (median values)	
	$p_N$ [bar]	$t_{1\ up}$	$t_{2\ up}$
06-10...10	100	35	60

1) Permissible pressure spikes

### Characteristics PV7-../06-10

▼ PV7-../06-10....A0-05...

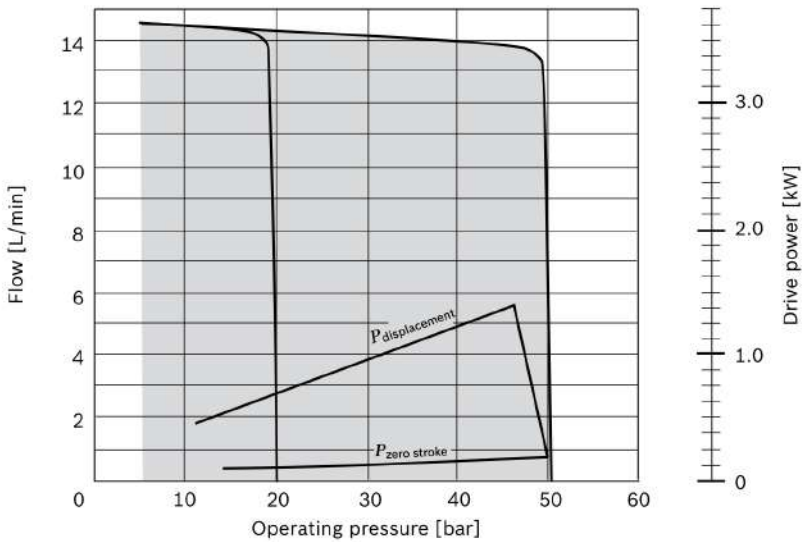

▼ PV7-../06-10....A0-10...

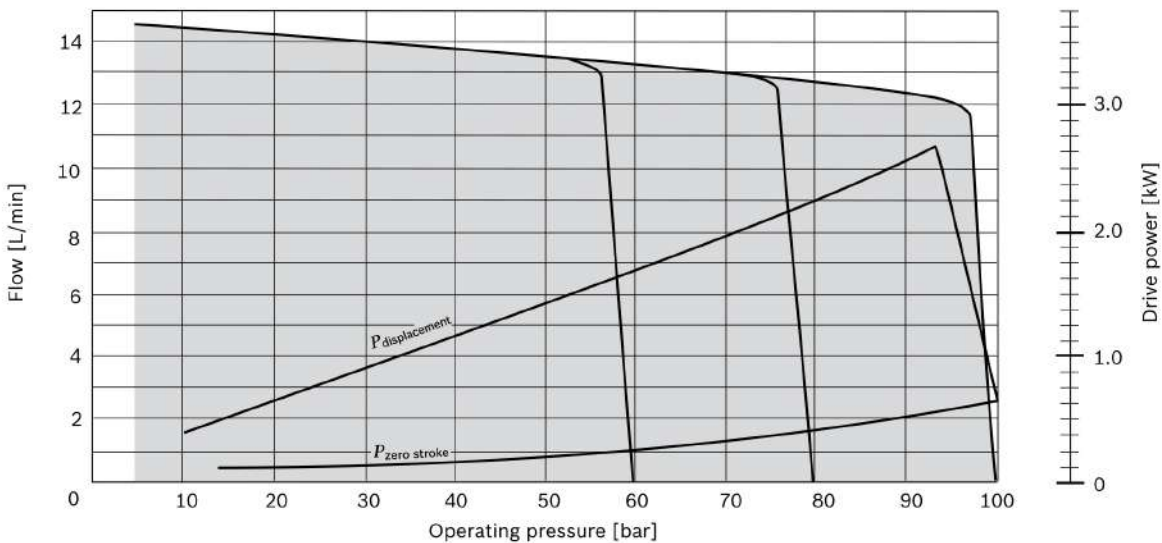

▼ Sound pressure level

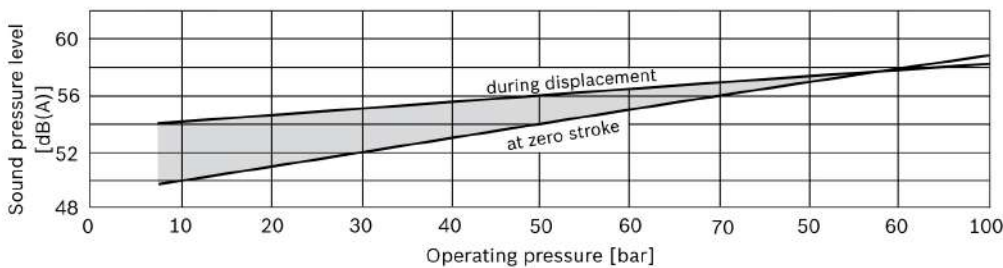

**Note**

Characteristics measured at  $n = 1450$  rpm;  $\nu = 41$  mm<sup>2</sup>/s;  $\theta = 50$  °C

Sound pressure level measured in acoustic room according to DIN 45635, page 26; distance: microphone – pump = 1 m

**Dimensions PV7-../06**

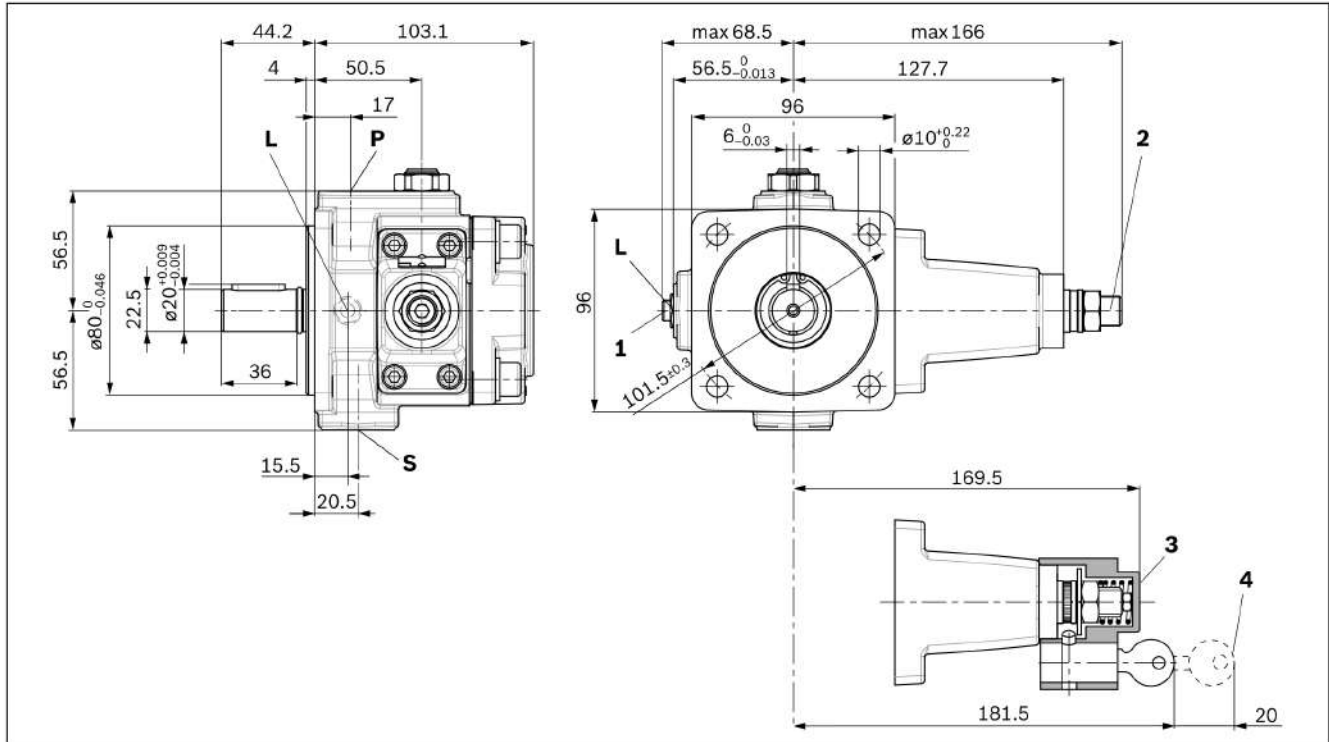

- 1 Flow adjustment
- 2 Pressure adjustment with adjustment screw (Standard), ordering code ...0...
- 3 Lock (optional), ordering code ...3...
- 4 Space required to remove key

**Notes for adjustments**

- ▶ Flow adjustment (1)
  - at clockwise rotation, decrease of flow
  - at counter clockwise rotation, increase of flow
- ▶ Pressure adjustment (2)
  - at clockwise rotation, increase of operating pressure
  - at counter clockwise rotation, decrease of operating pressure

**Ports**

Designation	Size
<b>S</b> Suction port	G1/2
<b>P</b> Pressure port	G3/8
<b>L</b> Case drain port	G1/4

## Commissioning instructions

### Air bleeding

- ▶ All of the PV7...A type vane pumps are self-priming.
- ▶ Before initial commissioning, the pump must be air-bled to protect it against damage.
- ▶ During the initial commissioning, we recommend to fill the housing through the case drain line. Take into account the filter grade! This increases operating safety and prevents wear in the case of unfavorable installation conditions.
- ▶ If the pump flow is not bubble-free after approx. 20 seconds, the system has to be rechecked. After the operating values have been reached, check the pipe connections for leakage and check the operating temperature.

### Commissioning

- ▶ Check whether the system is thoroughly and properly installed.
- ▶ Take into account the motor and pump direction of rotation arrows.
- ▶ Start the pump without load and let the flow run without pressure for a few seconds in order to provide sufficient lubrication.
- ▶ **On no account let the pump run without hydraulic fluid!**

### Note

- ▶ Adjustment, maintenance and repair of the pump may only be carried out by authorized, trained and instructed personnel!
- ▶ Use only original Rexroth spare parts!
- ▶ The pump may only be operated within the permissible data.
- ▶ The pump may only be operated when in perfect condition!
- ▶ When carrying out any work on the pump (e.g. mounting and removal) switch the system to zero pressure and isolate from the mains supply!
- ▶ Unauthorized conversions and changes, affecting the safety and function are not permissible!
- ▶ Mount safety devices (e.g., coupling protection)!
- ▶ Do not remove any existing safety devices!
- ▶ The generally valid safety and accident prevention regulations must be adhered to!



## HI-TECH HYDRAULICS

K-18 Sonal Industrial Estate, Link Road, Kachpada,  
Malad West, Mumbai – 400064, INDIA.

+91 8433648864 / 022 79692008

[hitechhydraulics9@gmail.com](mailto:hitechhydraulics9@gmail.com)

[www.hitechhyd.com](http://www.hitechhyd.com)