

Certificates



Explosion Isolation Solenoid Check Valve

Technical specification



Specification	06	10
Max. working pressure (MPa)	31.5	
Max. Flow (L/min)	220	430
Working fluid	Mineral oil; phosphate-ester	
Fluid temp. (°C)	-20~70	
Viscosity (mm²/s)	2.8~380	
Opening pressure (MPa)	a: 0.05 b: 0.4	
Working voltage (V)	DC	24
	AC ⁽²⁾	127/50Hz 220/50Hz
Insulation grade	IP55	
Cleanliness	The maximum allowable cleanliness of the oil should be according to 9th degree of Standard NAS1638. It is suggested that the minimum filter rating should be β 10 ≥ 75.	

- 1) Working voltage is relative to the explosion-proof type, details please refer to "Product introduction".
- 2) For voltage AC, rectifier is integrated with the solenoid, no need for external rectifying.

Model instruction

Explosion isolation solenoid check valve

Specification
02 DN6
03 DN10

Opening pressure
a=0.05MPa
b=0.4MPa

A N.C. Normally closed
B N.O. Normally open

Working voltage
D24 DC24V
B127 (AC127V Rectified)
B220 (AC220V Rectified)

Remarks
Serial number
Seal material
Omit NBR Seals
V FPM Seals

Omit without push rod emergency
N9 with concealed push rod emergency

Ex d I Mb
Ex d II C T6 Gb
E Ex d IIIC T80°C Db IP65

GDAW/ - * - * - * / * - * - * / * 52 *

The corresponding relation between the working pressure and the types of explosion isolation is specified in the page of "Product Brief".

Code symbol

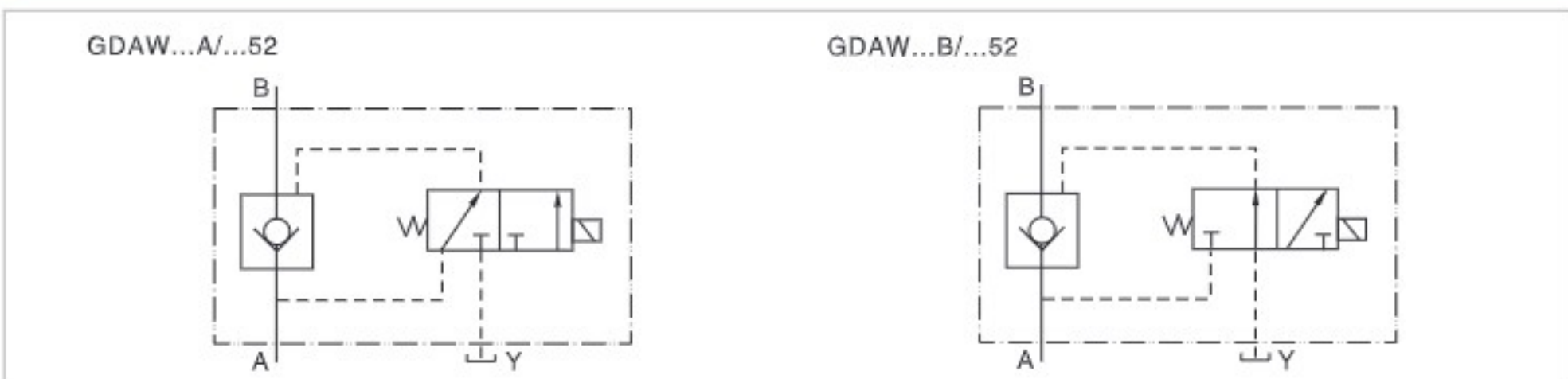

Explosion Isolation Solenoid Check Valve

External dimensions

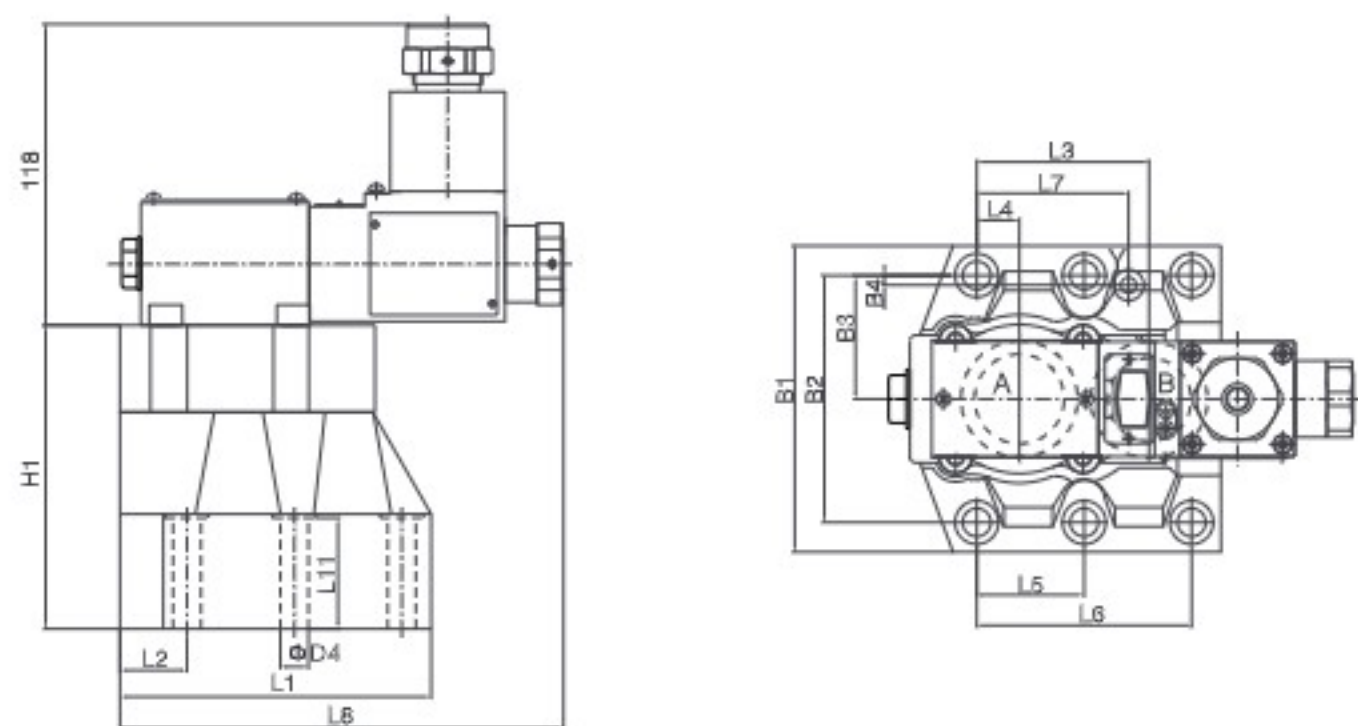

Specification	B1	B2	B3	B4	L1	L2	L3	L4	L5	L6	L7
GDAW-06	102	79.4	39.7	6.4	101	25	49.2	11.1	0	60.3	39.7
GDAW-10	120	96.8	48.4	3.8	122	26.3	67.5	16.7	42.1	84.2	59.5

Specification	L8	L9	L10	L11	L12	D1	D2	D3	D4	H1
GDAW-06	13.8	198	101	23	30	24	6	M10	11	95
GDAW-10	6.8	198	125	24	43.5	32	6	M10	11	119

Subplate size

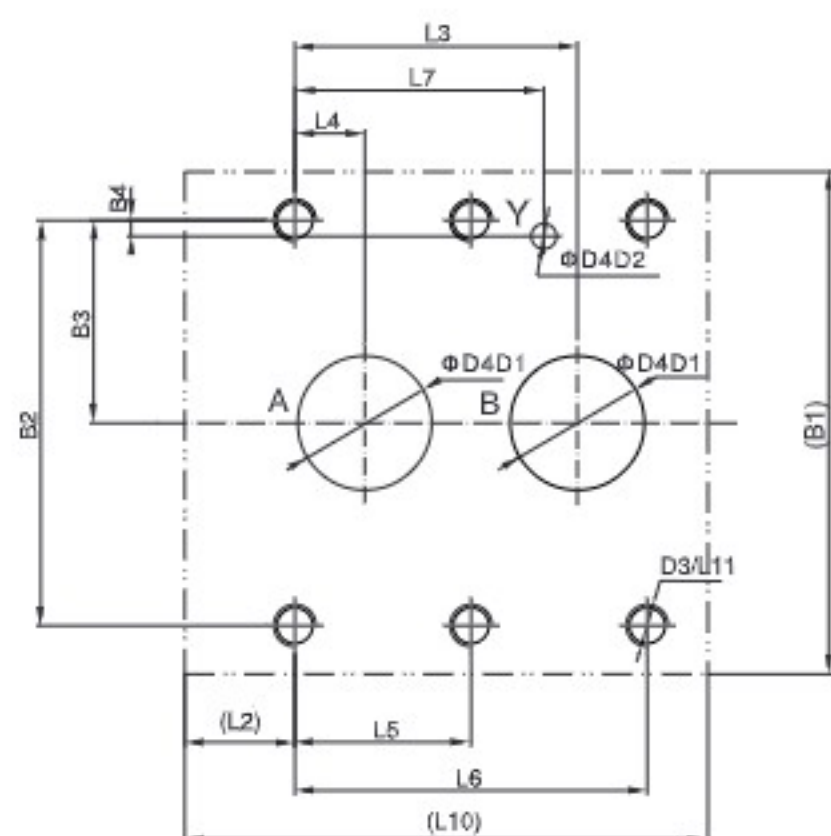

Specification	Fixing screw	Amount	Tighten torque
GDAW-06	M10x45-10.9	4	75Nm
GDAW-10	M10x60-10.9	6	75Nm

1. When installing the product, consider horizontal position firstly.
2. The medium used in the hydraulic system must be filtered. Its accuracy at least should be 20 μm.
3. Screw should be according to the parameters of catalogue.
4. The surface, connecting with the valve, should be Ra0.8 roughness, and 0.01/100mm flatness.

Explosion Isolation Solenoid Directional Control Valve

Technical specification



Specification		02	03
Max. working pressure (MPa)	Oil ports P, A, B	31.5	
	Oil port T	10	
Max. Flow (L/min)		80	120
Working fluid		Mineral oil; phosphate-ester	
Fluid temp. (°C)		-20~70	
Viscosity (Mm²/s)		2.8~380	
Working voltage (V)	DC	24	*AC
	*AC	127, 220	
Cycle time (ms)	Open	25~45	10~20
	Close	10~25	15~40
Max. switch frequency (t/h)		15000	7200
Insulation grade		IP55	
Cleanliness	The maximum allowable cleanliness of the oil should be according to 9th degree of Standard NAS1638. It is suggested that the minimum filter rating should be β ₁₀ ≥ 75.		

- 1) Working voltage is relative to the explosion-proof type, details please refer to "Product introduction".
- 2) For voltage AC, rectifier is integrated with the solenoid, no need for external rectifying.

Model instruction

GDFW - * - * - * * * / * * 52 *		Remarks
Explosion isolation solenoid directional control valve		
Specification	02 DN 6 03 DN 10	Serial number
Function code	Details as following symbol table	Seal material Omit NBR Seals V FPM Seals
Working voltage	D24 DC24V B127 (AC127V Rectified) B220 (AC220V Rectified)	Omit No damping 08 Φ0.8 Damping 10 Φ1.0 Damping 12 Φ1.2 Damping
E	Ex d I Mb Ex d II C T6 Gb Ex d IIIC T80°C Db IP65	Omit without push rod emergency N9 with concealed push rod emergency

Notice: The corresponding relation between the working pressure and the types of explosion isolation is specified in the page of "Product Brief".