

## Hydraulic-operated Directional Control Valve

### Dimension

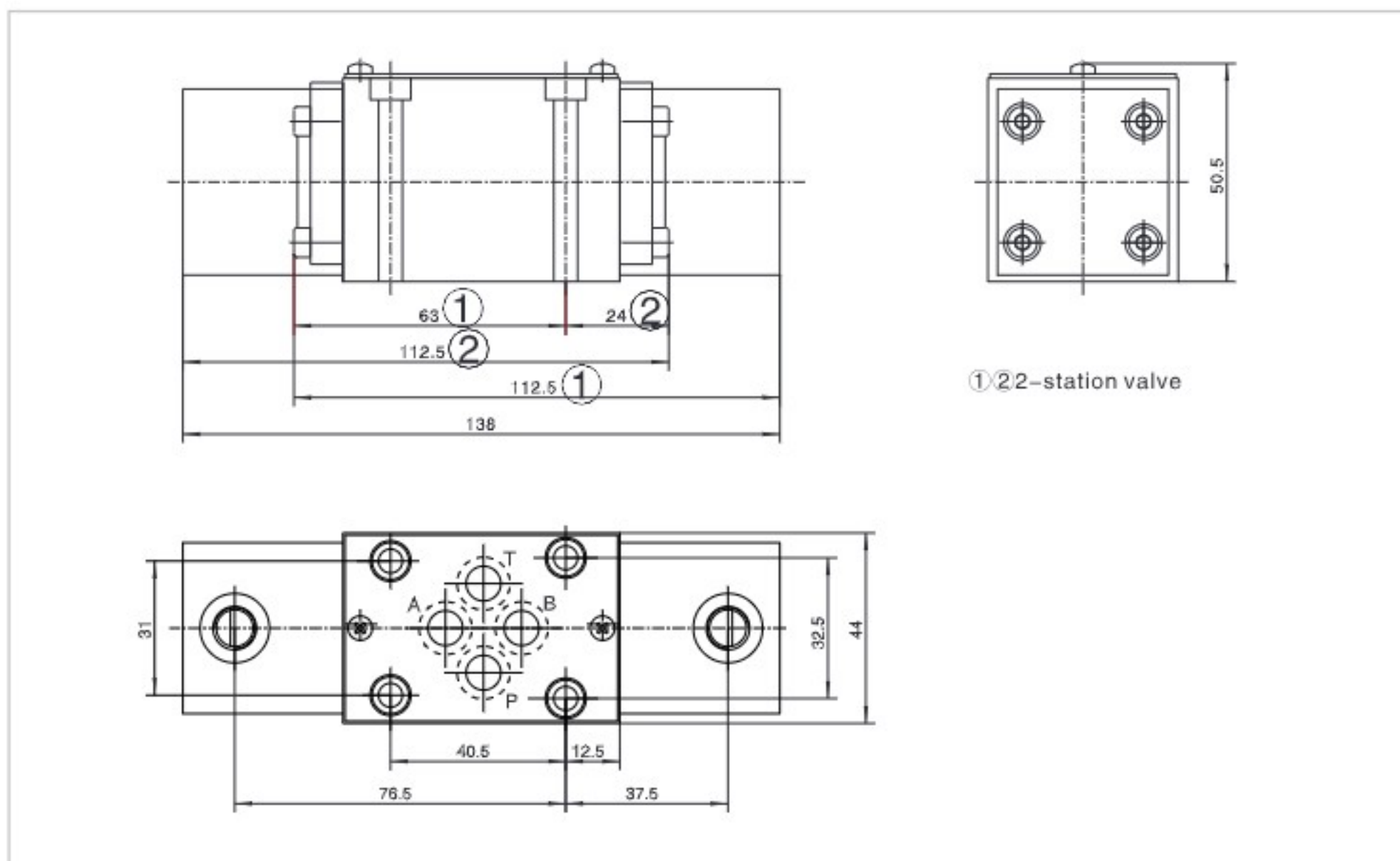

### Subplate size

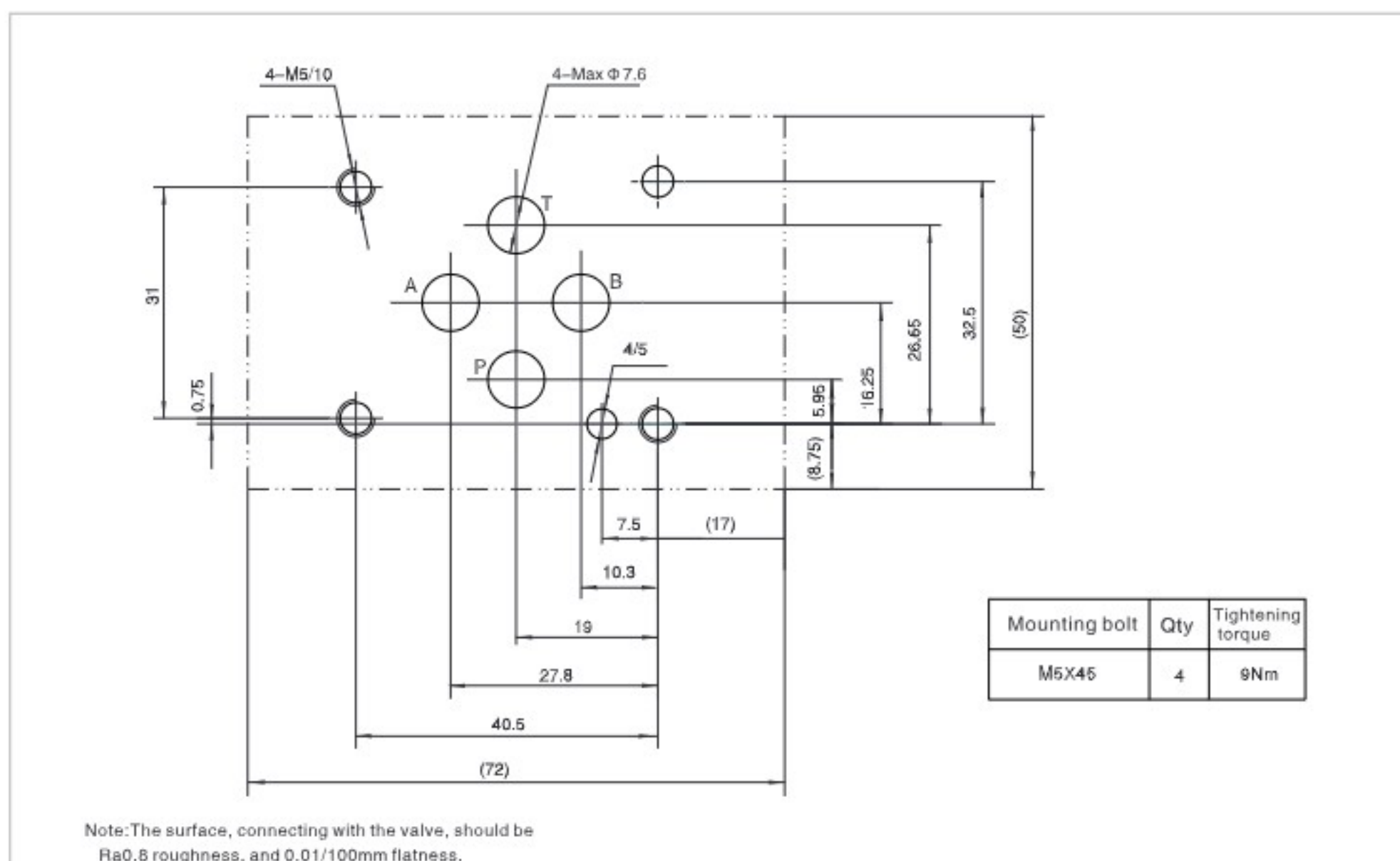

## Water-proof Electrical Operated Directional Control Valve

### Technical specification



Specification	02	
Working pressure (MPa)	Oil ports P, A, B	31.5
	Oil port T	10
Max. Flow (L/min)	80	
Working fluid	Mineral oil; phosphate-ester	
Fluid temp. (°C)	-20~70	
Viscosity (mm <sup>2</sup> /s)	2.8~380	
Working voltage (V)	DC 12 24	
Max. Switch frequency (T/h)	15000	
Insulation grade	Ip65	
Cleanliness	The maximum allowable cleanliness of the oil should be according to 9th degree of Standard NAS1638. It is suggested that the minimum filter rating should be β 10 ≥ 75.	

Water-proof electrical operated directional control valve uses solenoid to pull the spool and change the direction of the hydraulic oil.

Water-proof electrical operated directional control valve can directly control the start, stop and direction of a fluid flow. It also can be used as the pilot-operated valve, which could operate other valves.

Supplement: Water-proof electrical operated directional control valve is usually used at damp environment such as garbage trucks.

### Model description

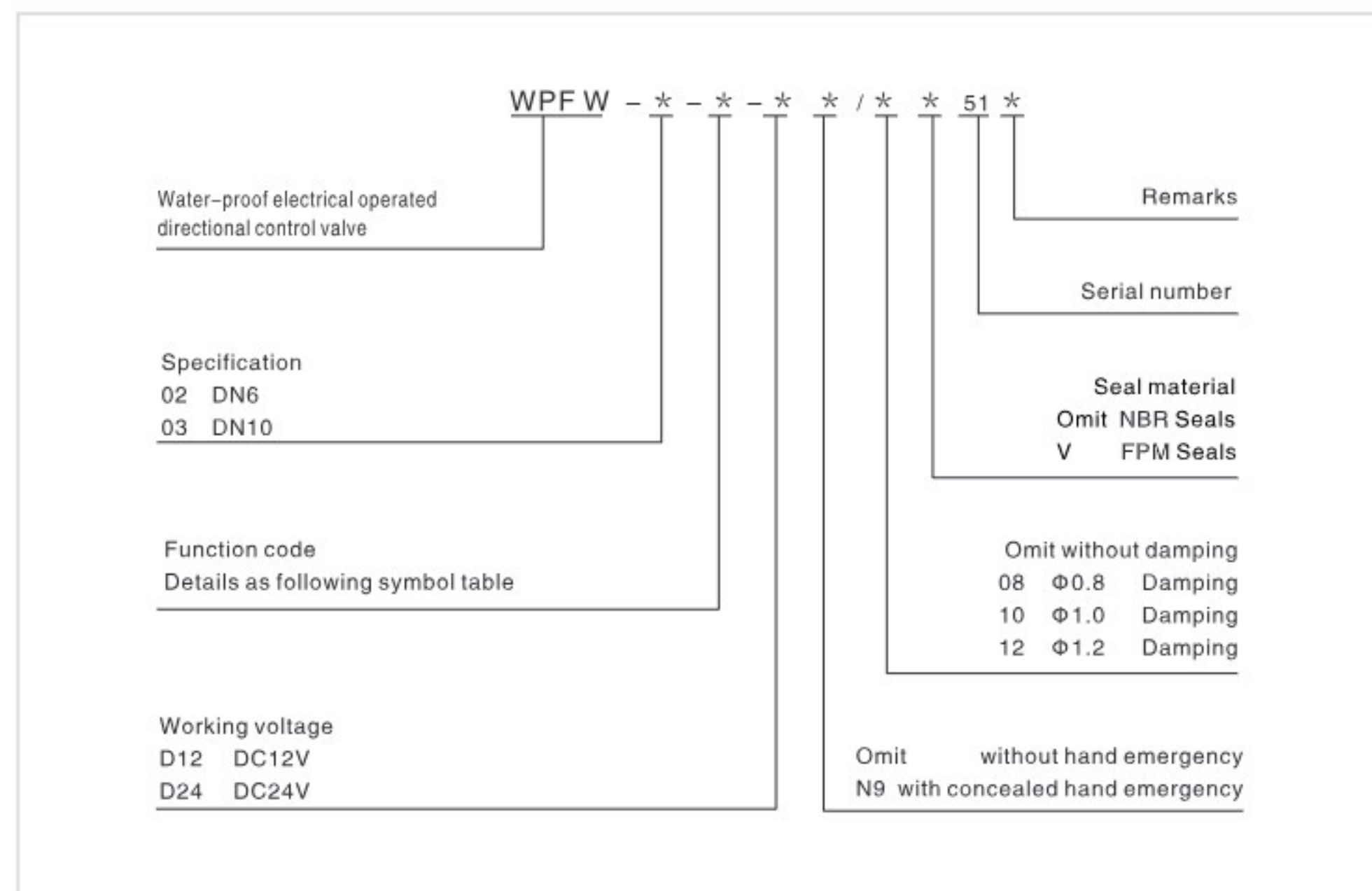

Water-proof Electrical Operated Directional Control Valve

Code symbol

Spring return

3C2		2B2B		2B2BL	
3C3		2B3B		2B3BL	
3C4		2B4B		2B4BL	
3C5		2B5B		2B5BL	
3C6		2B6B		2B6BL	
3C7		2B7B		2B7BL	
3C9		2B9B		2B9BL	
3C10		2B10B		2B10BL	
3C11		2B11B		2B11BL	
3C12		2B12B		2B12BL	
3C25		2B25B		2B25BL	
3C29		2B29B		2B29BL	

Water-proof Electrical Operated Directional Control Valve

Name of solenoid

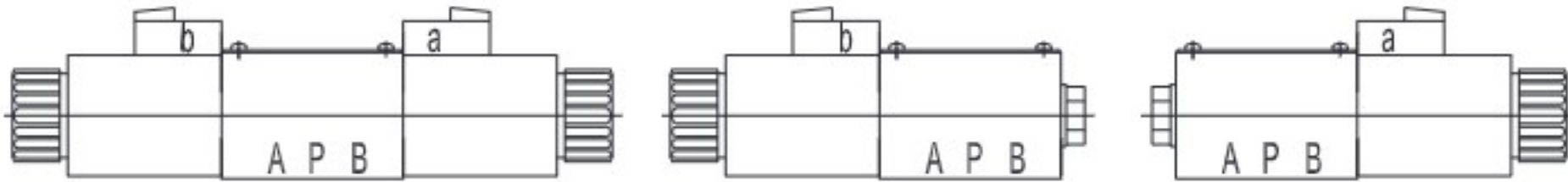

1. a When movement a, P→A B→T
2. b When movement b, P→B A→T
3. 3C5,3C6 Oil flow in the opposite direction with the above-mentioned movement.

Specification Performance curve ( Measured at  $v=41\text{mm}^2/\text{s}$  and  $t=50^\circ\text{C}$  )

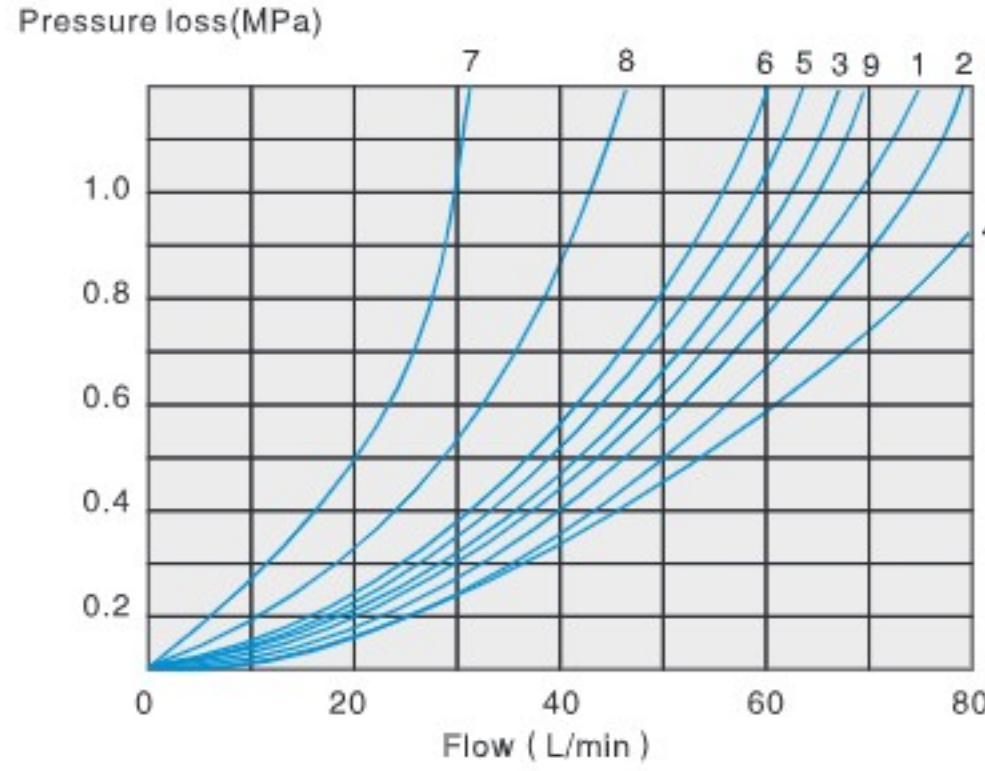

Function code	Direction			
	P→A	P→B	A→T	B→T
2B8 2B8L	3	3	-	-
2B3	1	1	3	1
2B2 2B2L	5	5	3	3
3C2	3	3	1	1
3C5	1	3	1	1
3C6	6	6	9	9
3C3	2	4	2	2
3C4	1	1	2	1
3C10 3C12	3	3	4	9
3C9	2	3	3	3
C25	3	1	1	1
3C29	5	5	4	-
3C7	1	2	1	1

7. Spool type "3C29" located in the control position A → B  
8. Spool symbol 3C6 in the median position P → T

# Water-proof Electrical Operated Directional Control Valve

**Specification Working limits** (The working limits for directional valve have determined by using solenoids at their operating temperature, 10% under voltage and with no pre-loading of the tank.)

With regard to the four-way valve, the normal flow data as shown is get from the regular use of two directions of the flow (e.g.P to A, and simultaneous return flow from B to T). See tables. If only one flow direction is needed, for example: When a four port valve which is closed up port A or port B, used as a three-way valve, the Maximum flow may be very small in the serious condition.

DC solenoid operation DC D24, D1 2, B220, B110		AC solenoid operation AC A110, A220, 50HZ	
Curve	Symbol	Curve	Symbol
1	2B8 2B8L1)	11	
2	3C7	12	
3	2B8 2B8L	13	
4	3C5 3C25	14	
5	3C4	15	
6	3C6 3C3	16	
7	2N8 2D8 3C10 3C12	17	
8	2B3 2B2 2B2L	18	2B8 2B8L1)
9	3C9		3C7
10	3C2 3C29 2N3		2B8 2B8L
	2D3 2N2 2D2		3C5 3C25
			3C6
			3C3
			2N8 2D8 2N3 2D3
			2N2 2D2 3C2 3C4 3C10
			3C9 3C29 3C12
			2B3 2B2 2B2L

Working pressure(MPa)

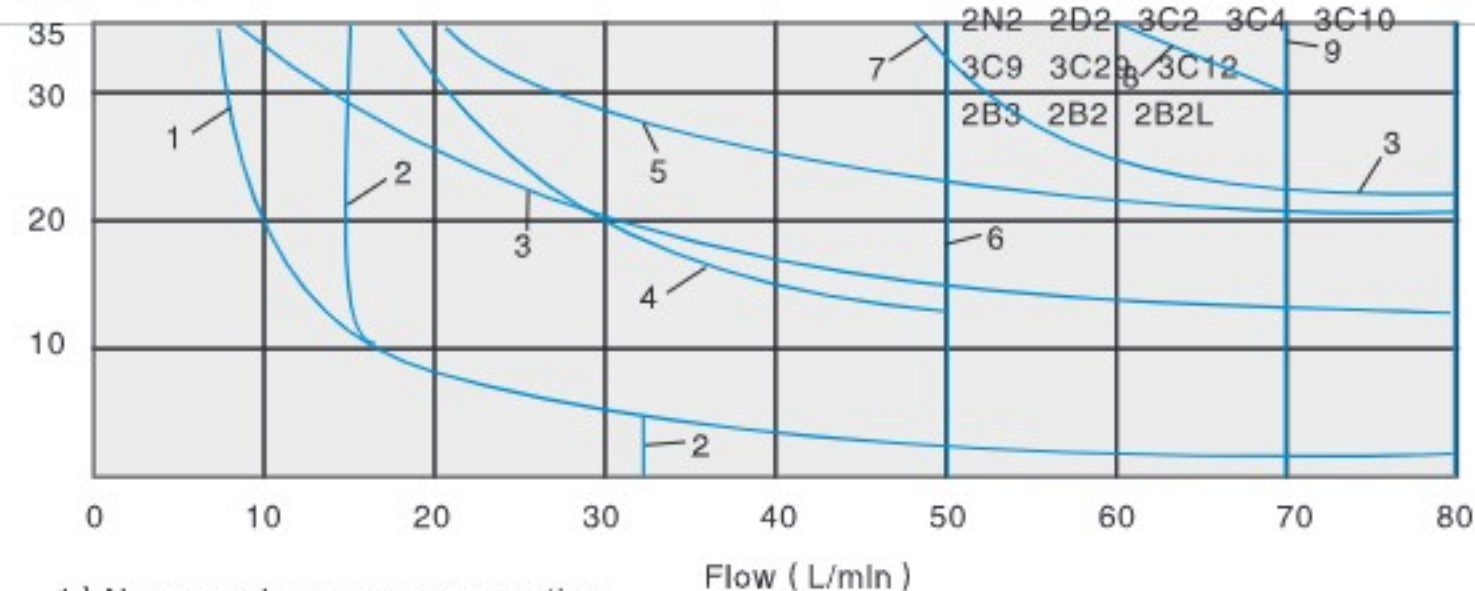

- 1) No manual emergency operation
- 2) Oil return from actuator to oil tank

Working pressure(MPa)

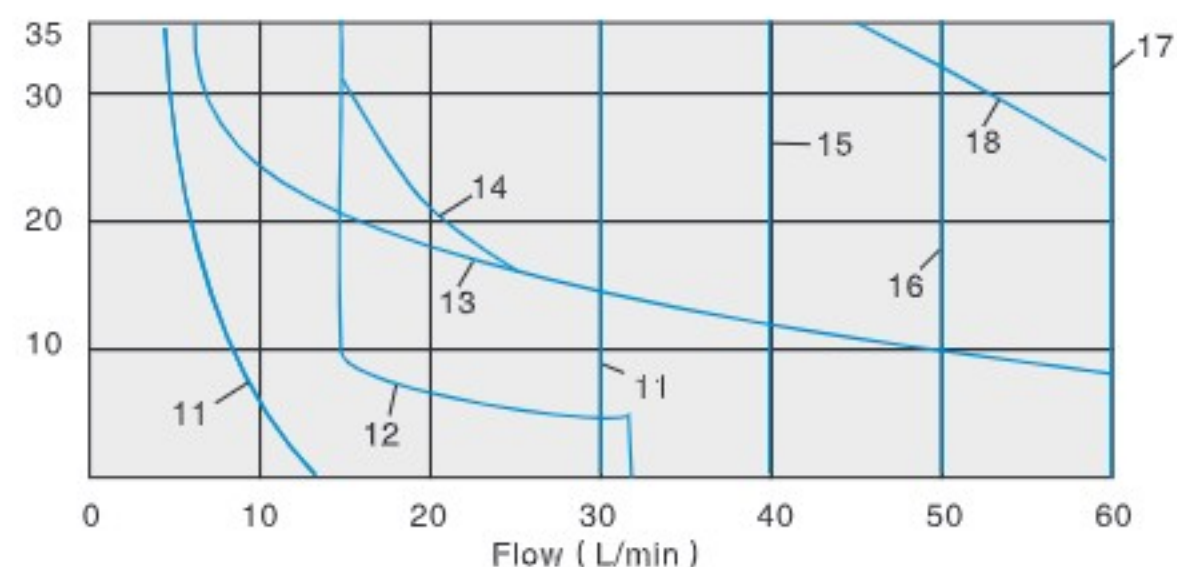

# Water-proof Electrical Operated Directional Control Valve

## External dimensions

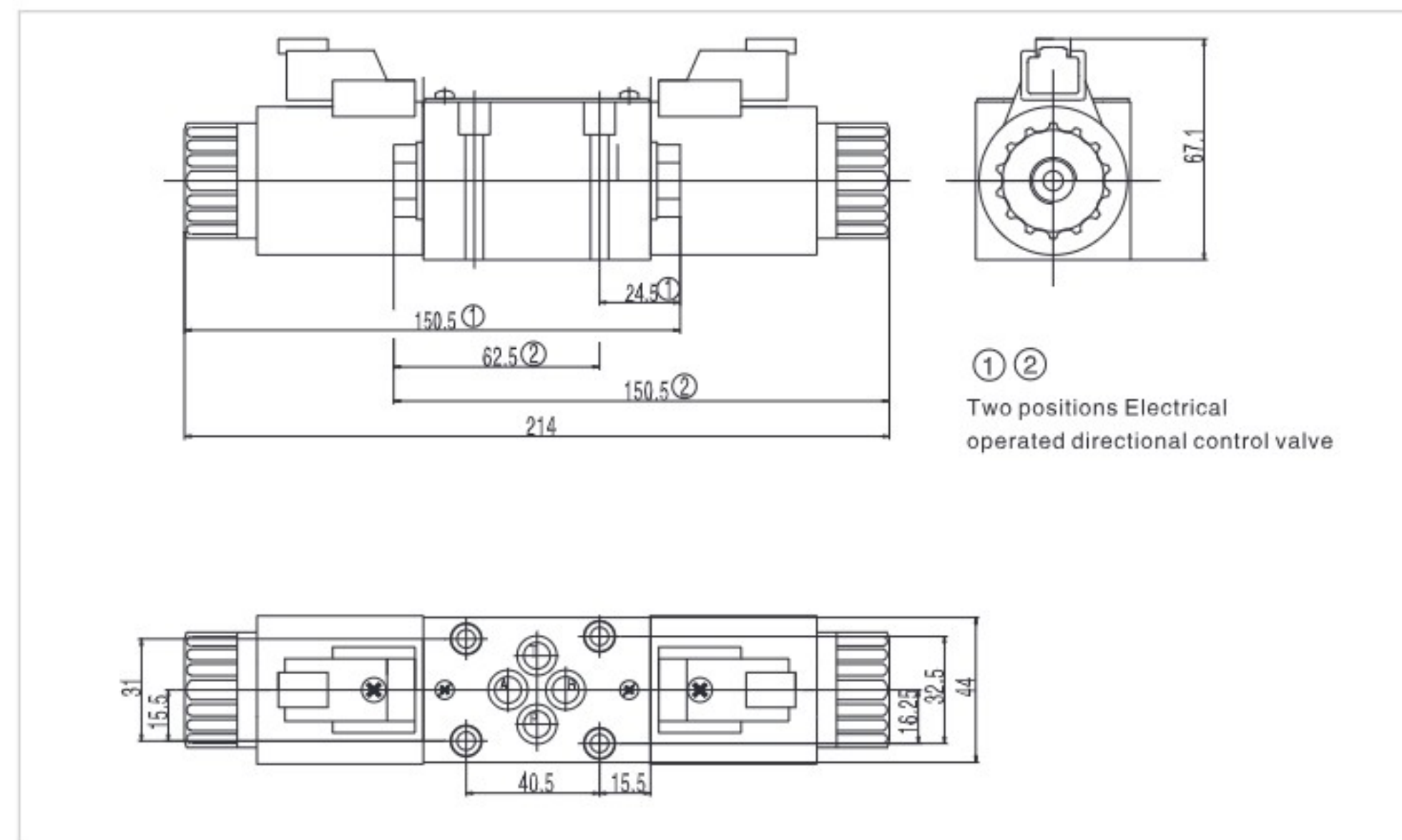

## Size of subplate oil port

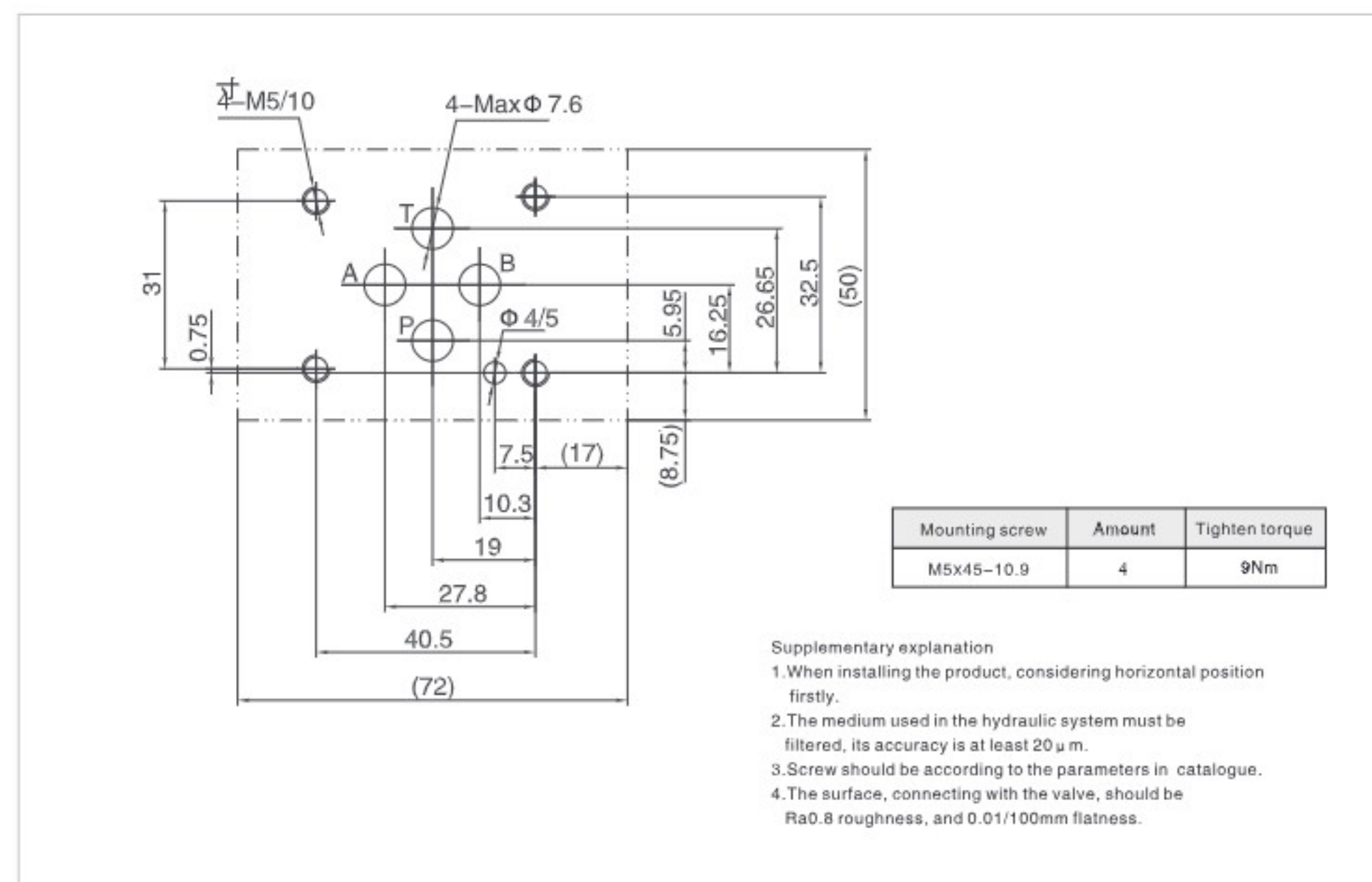

- Supplementary explanation
1. When installing the product, considering horizontal position firstly.
  2. The medium used in the hydraulic system must be filtered, its accuracy is at least 20 μm.
  3. Screw should be according to the parameters in catalogue.
  4. The surface, connecting with the valve, should be Ra0.8 roughness, and 0.01/100mm flatness.

## Water-proof Electrical Operated Directional Control Valve

### External dimensions

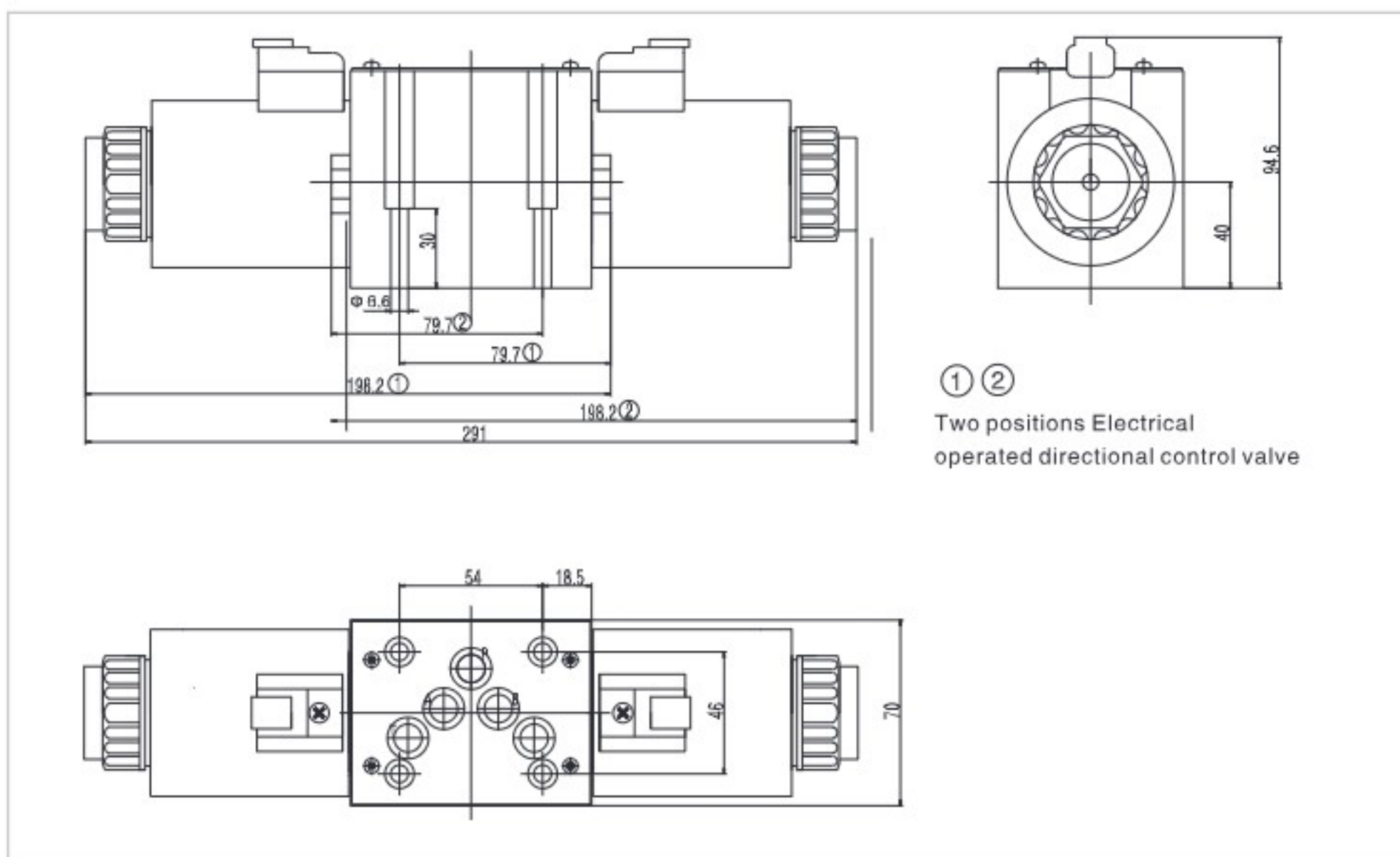

### Size of subplate oil port

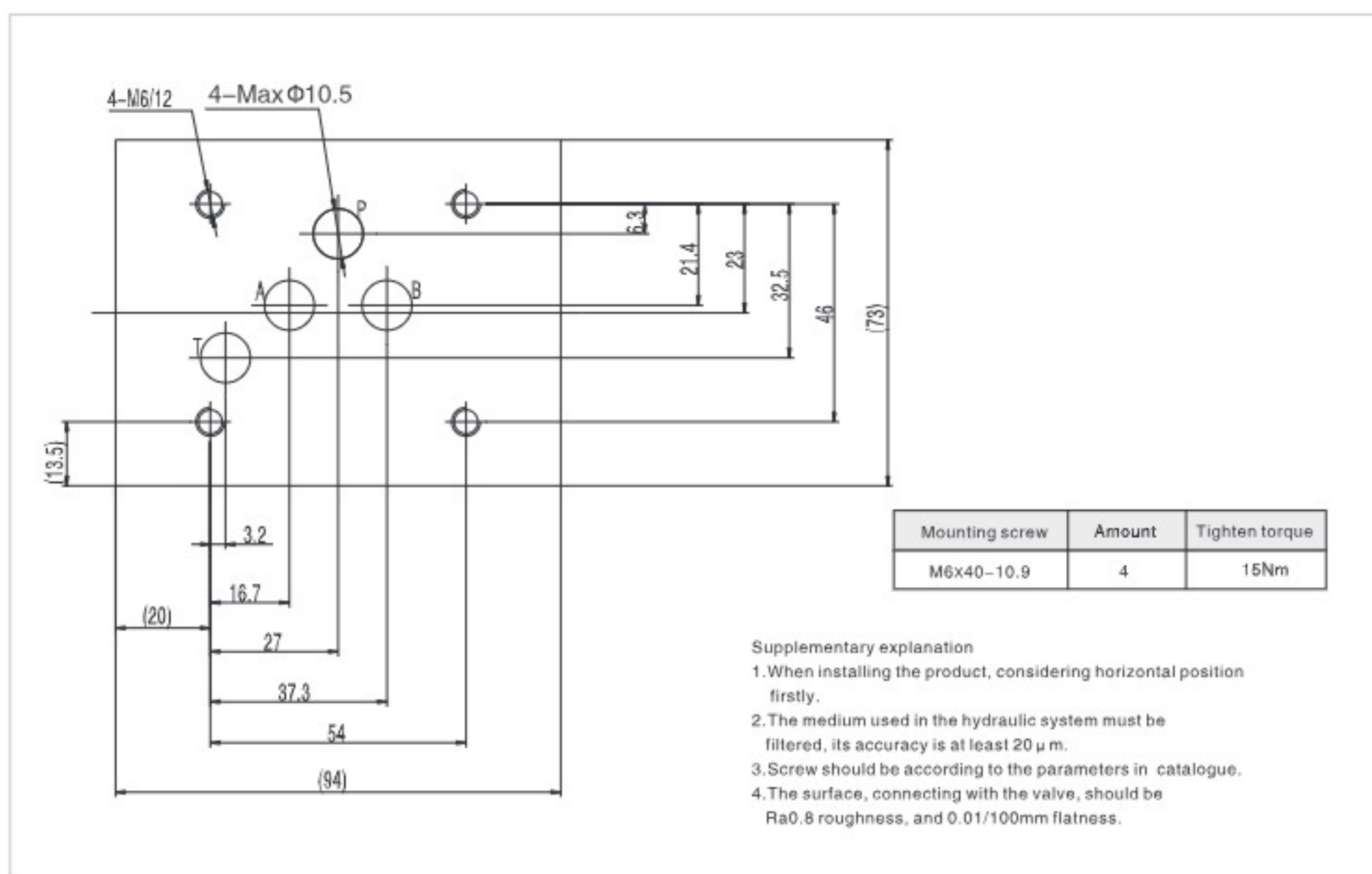

## Modular Check Valve

### Technical specification



Specification	02	03
Max. working pressure (MPa)	31.5	
Max. Flow (L/min)	40	100
Working fluid	Mineral oil; phosphate-ester	
Fluid temp. (°C)	-20~70	
Viscosity (mm <sup>2</sup> /s)	2.8~380	
O pening pressure (MPa)	a:0.05 b:0.25 c:0.4	
Cleanliness	The maximum allowable cleanliness of the oil should be according to 9th degree of Standard NAS1638. It is suggested that the minimum filter rating should be β 10 ≥ 75.	

### Model description

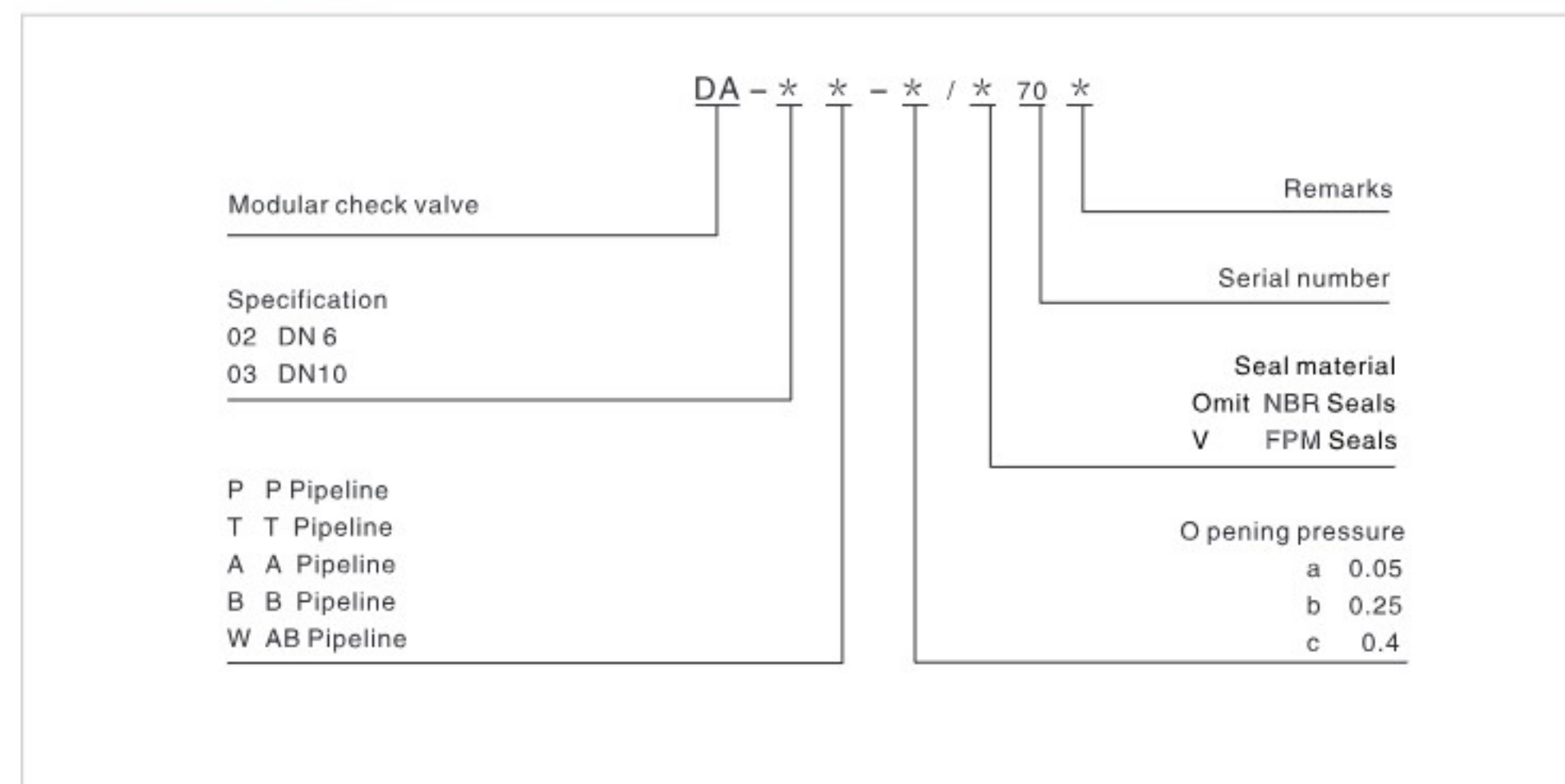

### Code symbol

