

# Electrical Operated Directional Control Valve

## Technical specification



Specification		02	03
Working pressure (MPa)	Oil ports P,A,B	35	31.5
	Oil port T	10	10
Max. Flow (L/min)		80	120
Working fluid	Mineral oil; phosphate-ester		
Fluid temp. (°C)	-20~70		
Viscosity (mm <sup>2</sup> /s)	2.8~100		
Working voltage (V)	DC	12	24
	AC	110/50Hz	220/50Hz
Max. Switch frequency (T/h)		15000 (DC)	7200 (AC)
Insulation grade	IP65		
Weight (kg)	Single solenoid	1.45(DC)	1.4(AC)
	Double solenoids	1.95(DC)	1.9(AC)
Cleanliness	The maximum allowable cleanliness of the oil should be according to 9th degree of Standard NAS1638. It is suggested that the minimum filter rating should be β <sub>10</sub> ≥ 75.		

## Model description

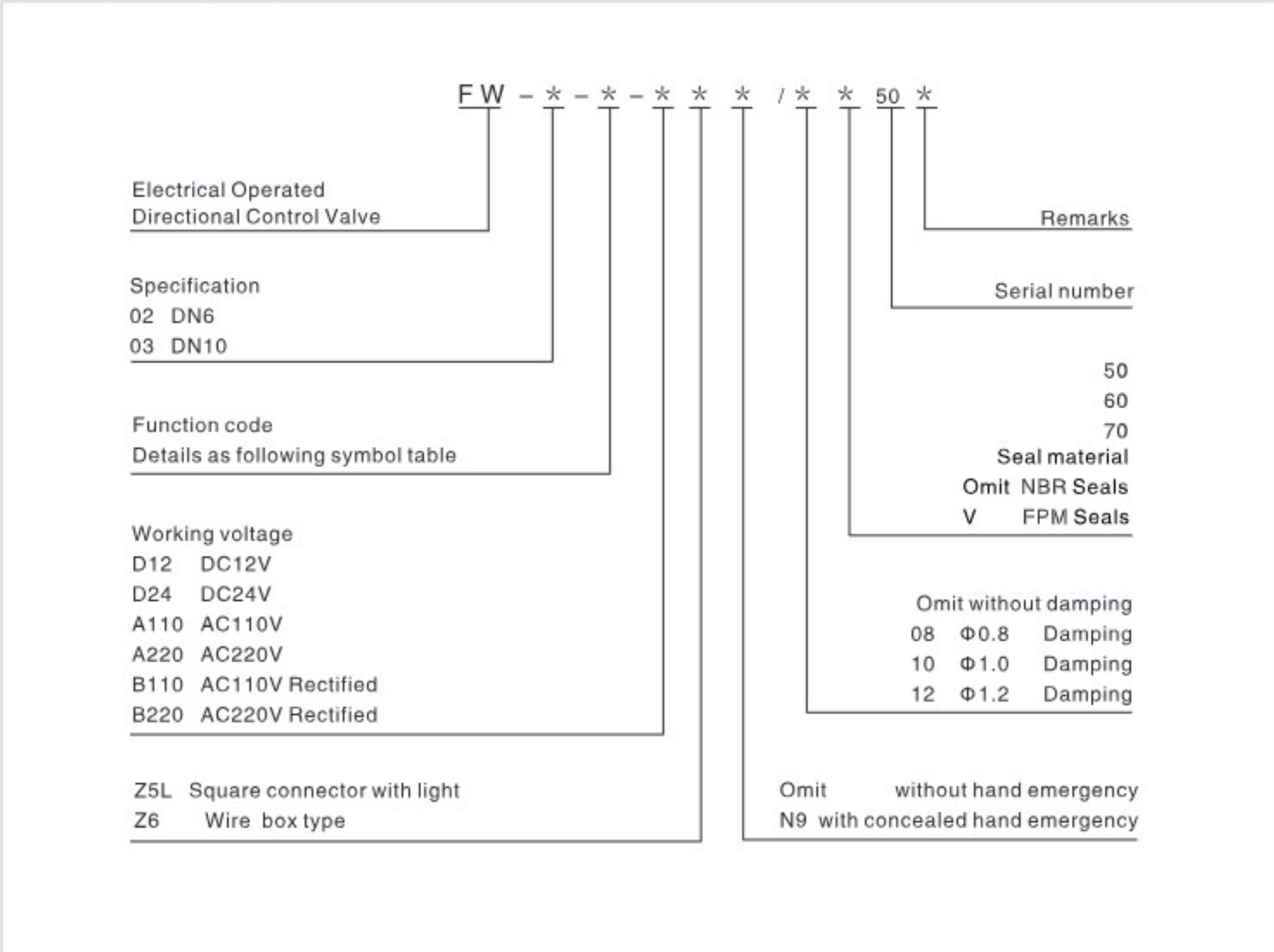

# Electrical Operated Directional Control Valve

## Code symbol

Spring return

3C2		2B2B		2B2BL		2B2	
3C3		2B3B		2B3BL		2B3	
3C4		2B4B		2B4BL		2B8	
3C5		2B5B		2B5BL		2B2L	
3C6		2B6B		2B6BL		2B3L	
3C7		2B7B		2B7BL		2B8L	
3C9		2B9B		2B9BL		With detent	
3C10		2B10B		2B10BL		2D2	
3C11		2B11B		2B11BL		2D3	
3C12		2B12B		2B12BL		2D8	
3C25		2B25B		2B25BL		No spring return and no detent mechanical positioning	
3C29		2B29B		2B29BL		2N2	
						2N3	
						2N8	

Note: \*D\* (No spring return mechanical positioning) solenoid directional control valve should be installed horizontally.



## Electrical Operated Directional Control Valve

### Name of solenoid

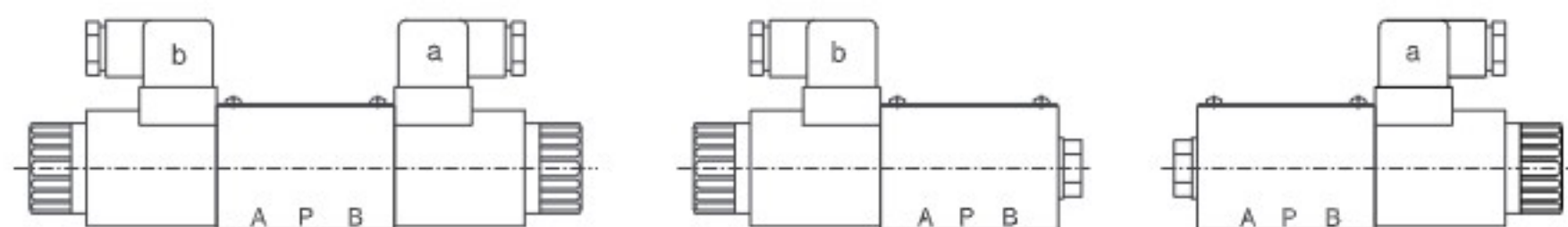

1. a When movement a, P→A B→T
2. b When movement b, P→B A→T
3. Oil flow in the opposite direction with the above-mentioned movement for 3C5、3C6symbol Valve.

### 02 Specification Performance curve ( Measured at $v=41\text{mm}^2/\text{s}$ and $t=50^\circ\text{C}$ )

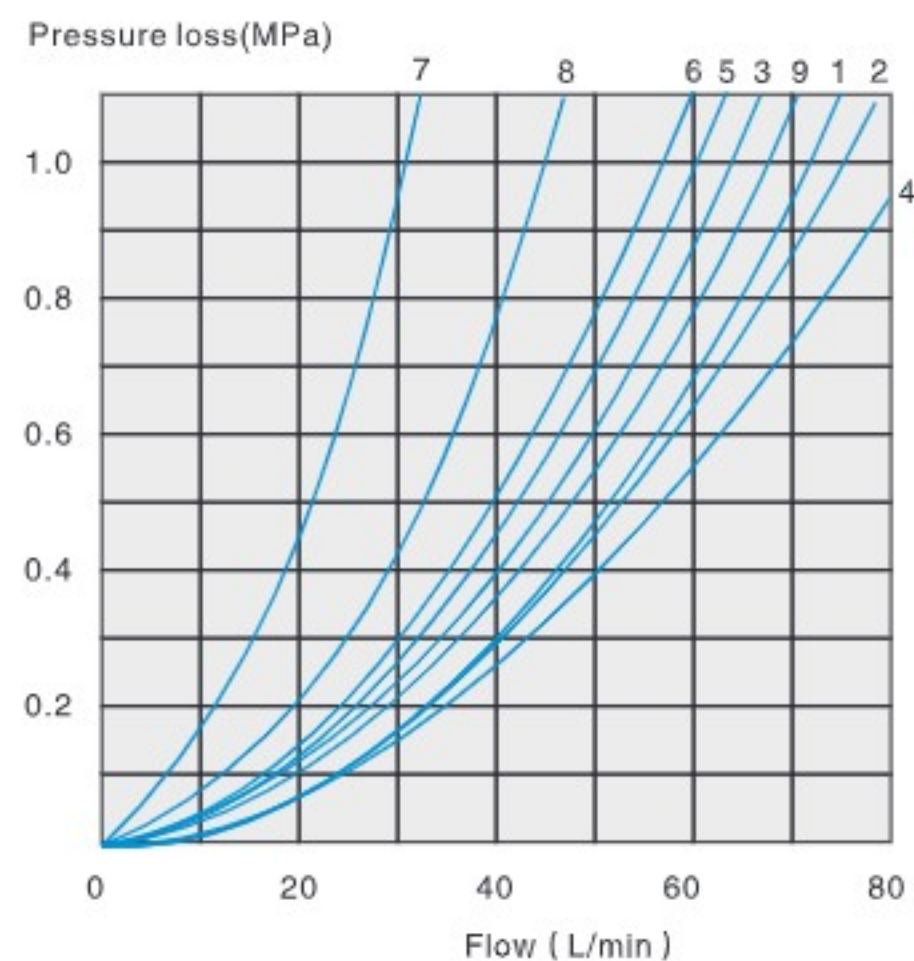

Function code	Direction			
	P→A	P→B	A→T	B→T
2B8 2B8L	3	3	-	-
2B3	1	1	3	1
2B2 2B2L	5	5	3	3
3C2	3	3	1	1
3C5	1	3	1	1
3C6	6	6	9	9
3C3	2	4	2	2
3C4	1	1	2	1
3C10,3C12	3	3	4	9
3C9	2	3	3	3
3C25	3	1	1	1
3C29	5	5	4	-
3C7	1	2	1	1

7. Spool type "3C29" located in the control position A→B
8. Spool symbol 3C6 in the neutral position P→T

## Electrical Operated Directional Control Valve

### 02 Specification Working limits (The working limits for directional valves have determined by using solenoids at their operating temperature, 10% under voltage and with no pre-loading of the tank)

With regard to the four-way valve, the normal flow data as shown is get from the regular use of two directions of the flow (e.g.P to A, and simultaneous return flow from B to T). See tables. If only one flow direction is needed, for example: When a four port valve which is closed up port A or port B, used as a three-way valve, the Maximum flow may be very small in the serious condition.

DC solenoid operation DC D24, D1 2, B220, B110		AC solenoid operation AC A110, A220, 50HZ	
Curve	Symbol	Curve	Symbol
1	2B8 2B8L 1)	11	
2	3C7	12	
3	2B8 2B8L	13	
4	3C5 3C25	14	
5	3C4	15	
6	3C6 3C3	16	
7	2N8 2D8 3C10 3C12	17	
8	2B3 2B2 2B2L		2B8 2B8L 1)
9	3C9		3C7
10	3C2 3C29 2N3 2D3 2N2 2D2	18	2B8 2B8L 3C5 3C25 3C6 3C3

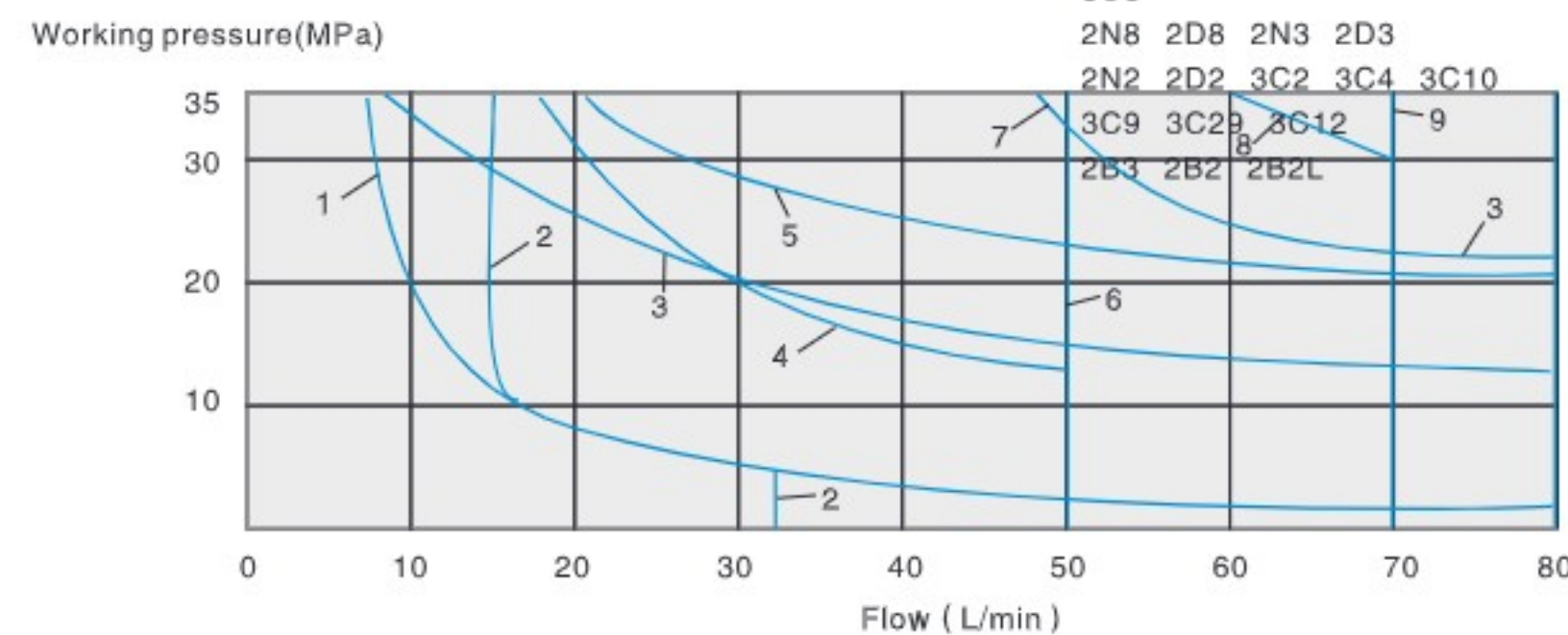

- 1) No manual emergency operation
- 2) Oil return from actuator to oil tank

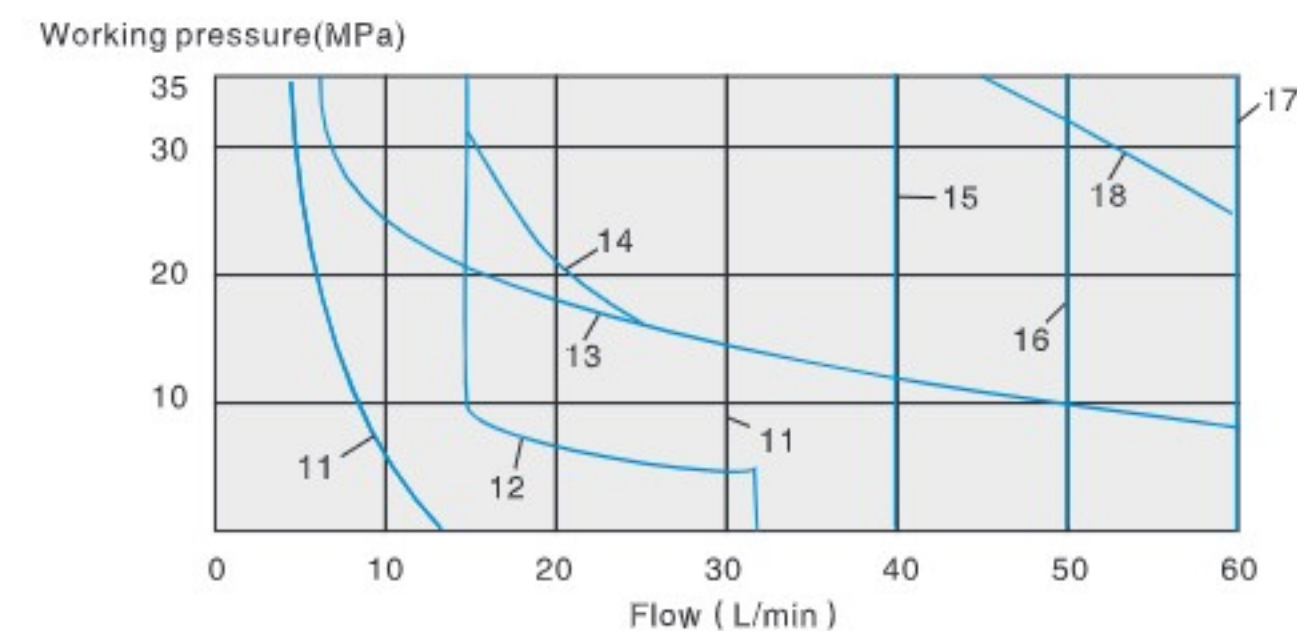



### Electrical Operated Directional Control Valve

**03 Specification** Performance curve ( Measured at  $v=41\text{mm}^2/\text{s}$  and  $t=50^\circ\text{C}$  )

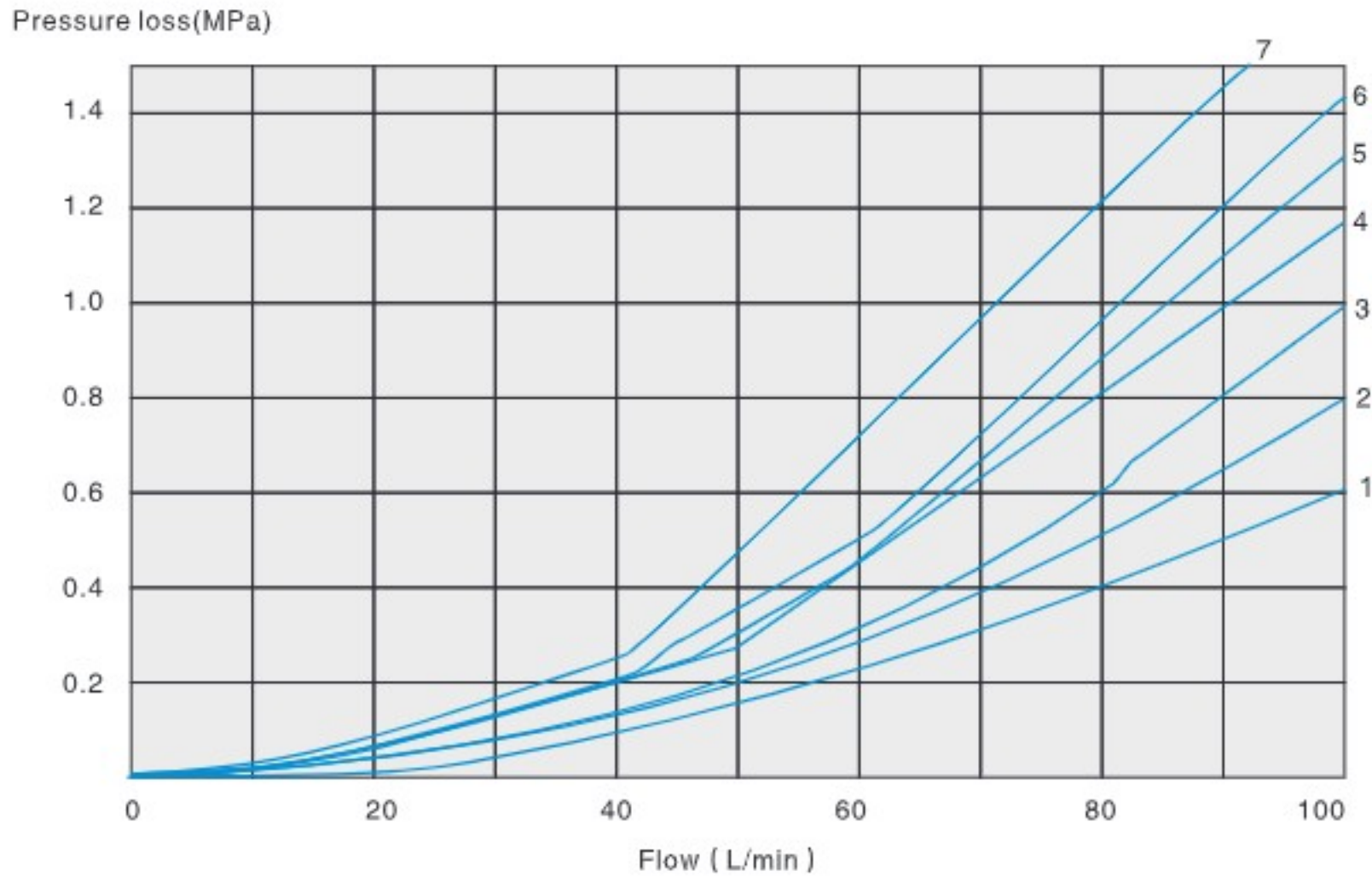

Function code	Direction			
	P→A	P→B	A→T	B→T
2B8 2B8L	2	2	-	-
2B3 2B2 2B2L	2	2	3	3
3C2 3C7	2	2	4	4
3C5	2	3	3	5
3C6	3	3	4	6
3C3	1	1	4	5
3C10 3C12	2	2	3	5
3C9	1	1	5	1
3C25	3	2	5	3
3C29	2	4	3	-

7. Spool symbol "3C29" in the shifting position A → B  
 4. Spool symbol 3C6 in neutral position P → T

D.5.5

### Electrical Operated Directional Control Valve

**03 Specification** Working limits (The working limits for directional valves have determined by using solenoids at their operating temperature, 10% under voltage and with no pre-loading of the tank)

With regard to the four-way valve, the normal flow data as shown is get from the regular use of two directions of the flow (e.g. P to A, and simultaneous return flow from B to T). See tables. If only one flow direction is needed, for example: When a four port valve which is closed up port A or port B, used as a three-way valve, the Maximum flow may be very small in the serious condition.

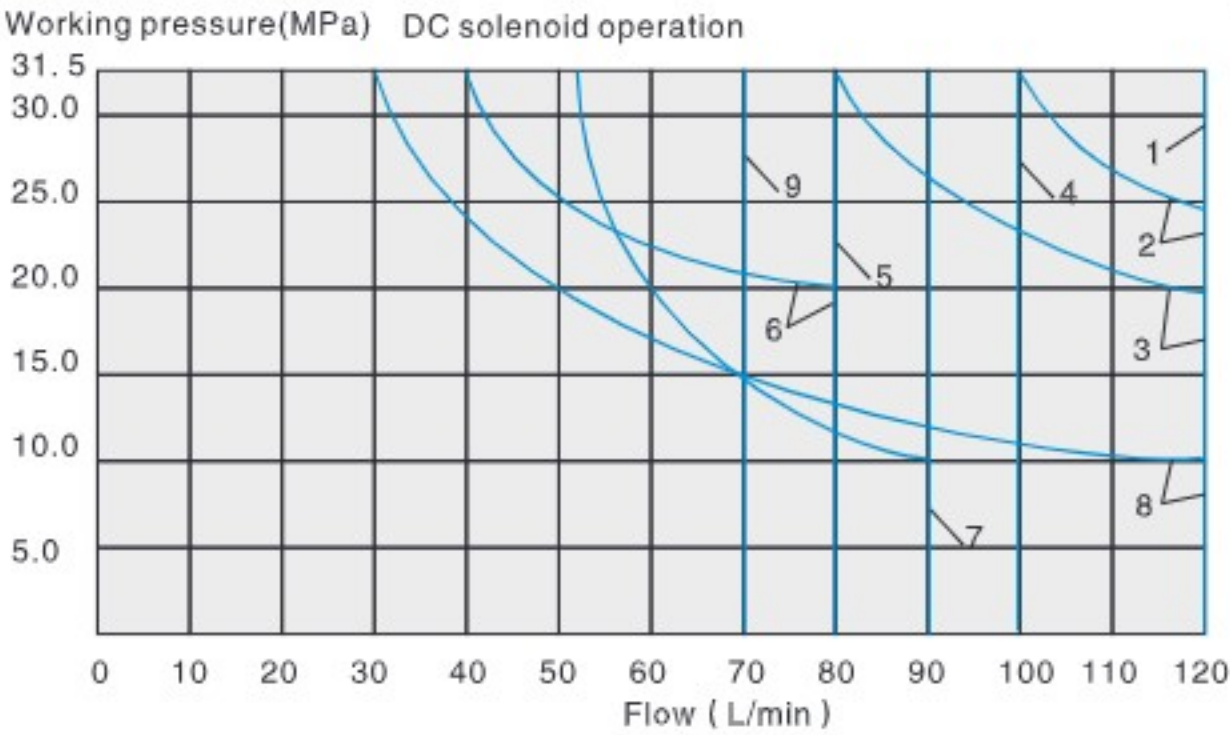

Curve	Symbol
1	2B3 2N3 2D3 2B2 2N2 2D2 2B2L 3C9
2	3C2
3	2N8 2D8 3C10 3C12 3C4
4	3C3
5	3C29
6	3C6
7	3C5 3C25
8	2B8 2B8L
9	3C7
1)	Return circuit (Independent of area ratio)

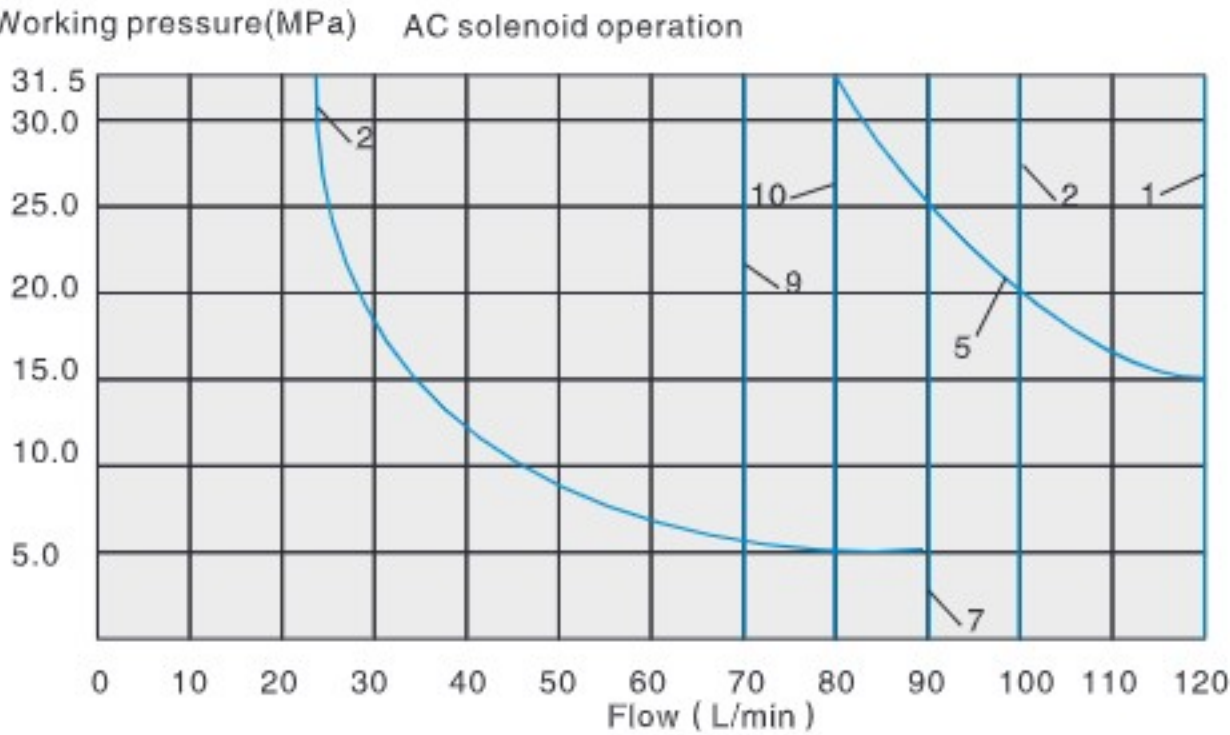

110V,50Hz; 120V,60Hz; 220V,50Hz; 240V,60Hz;	
Curve	Symbol
1	2B3 2N3 2D3 2B2 2N2 2D2 2B2L
2	3C2 3C10
3	3C12 3C9
4	2B8 2B8L
5	2N8 2D8 3C4
6	3C6
7	3C5 3C25
8	3C7
9	3C3
10	3C29

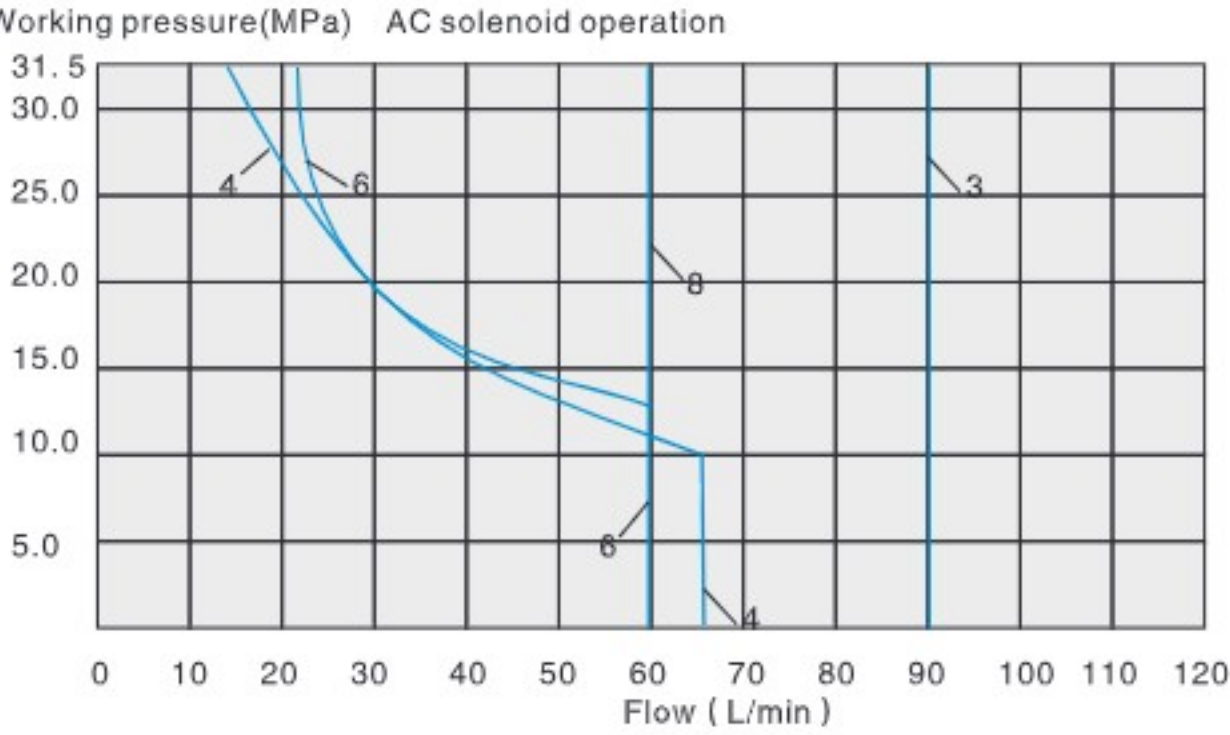

D.5.6



### Electrical Operated Directional Control Valve

External dimensions ( 02 Direct current plug type )

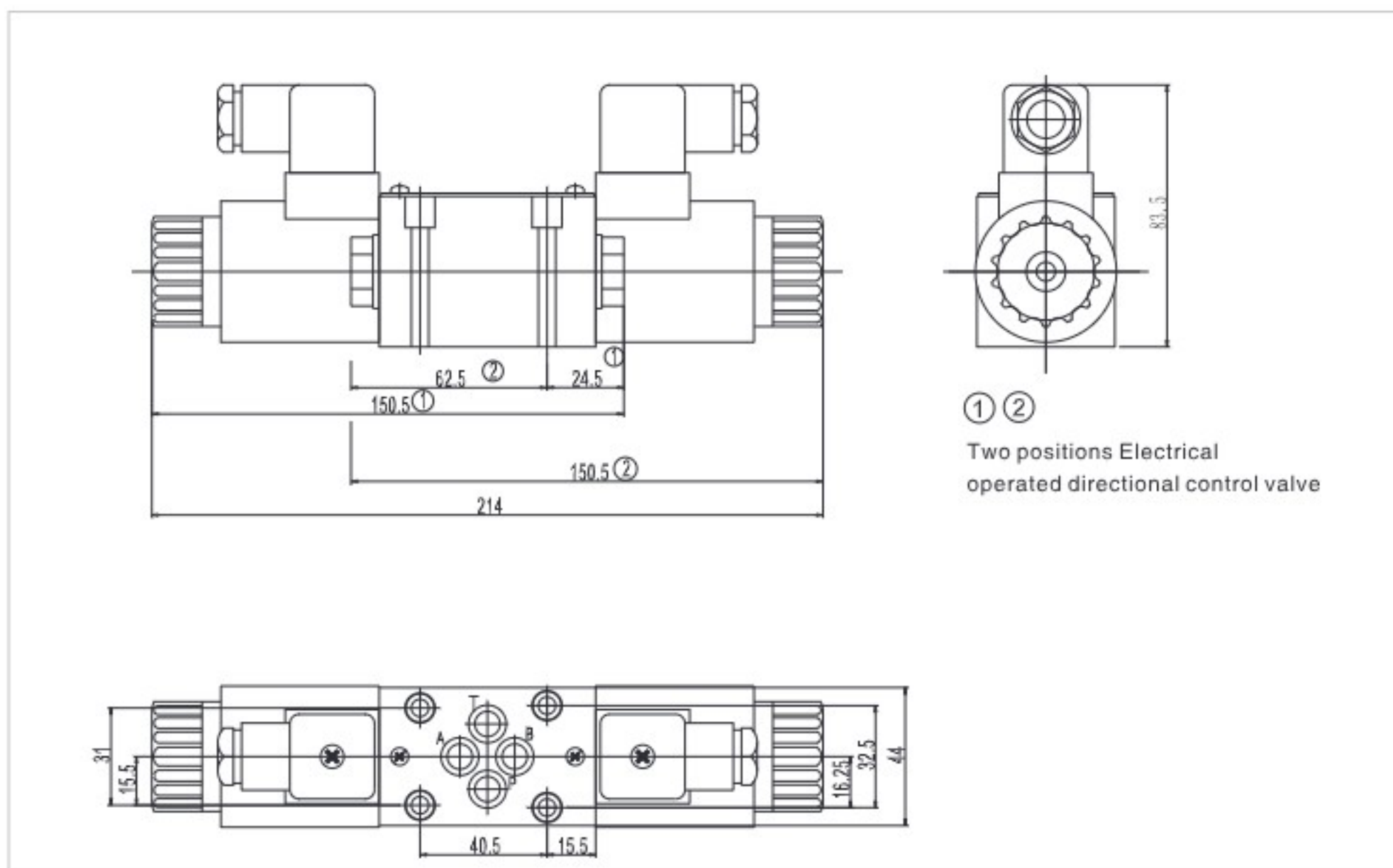

### Electrical Operated Directional Control Valve

External dimensions ( 02 Alternating current plug type )

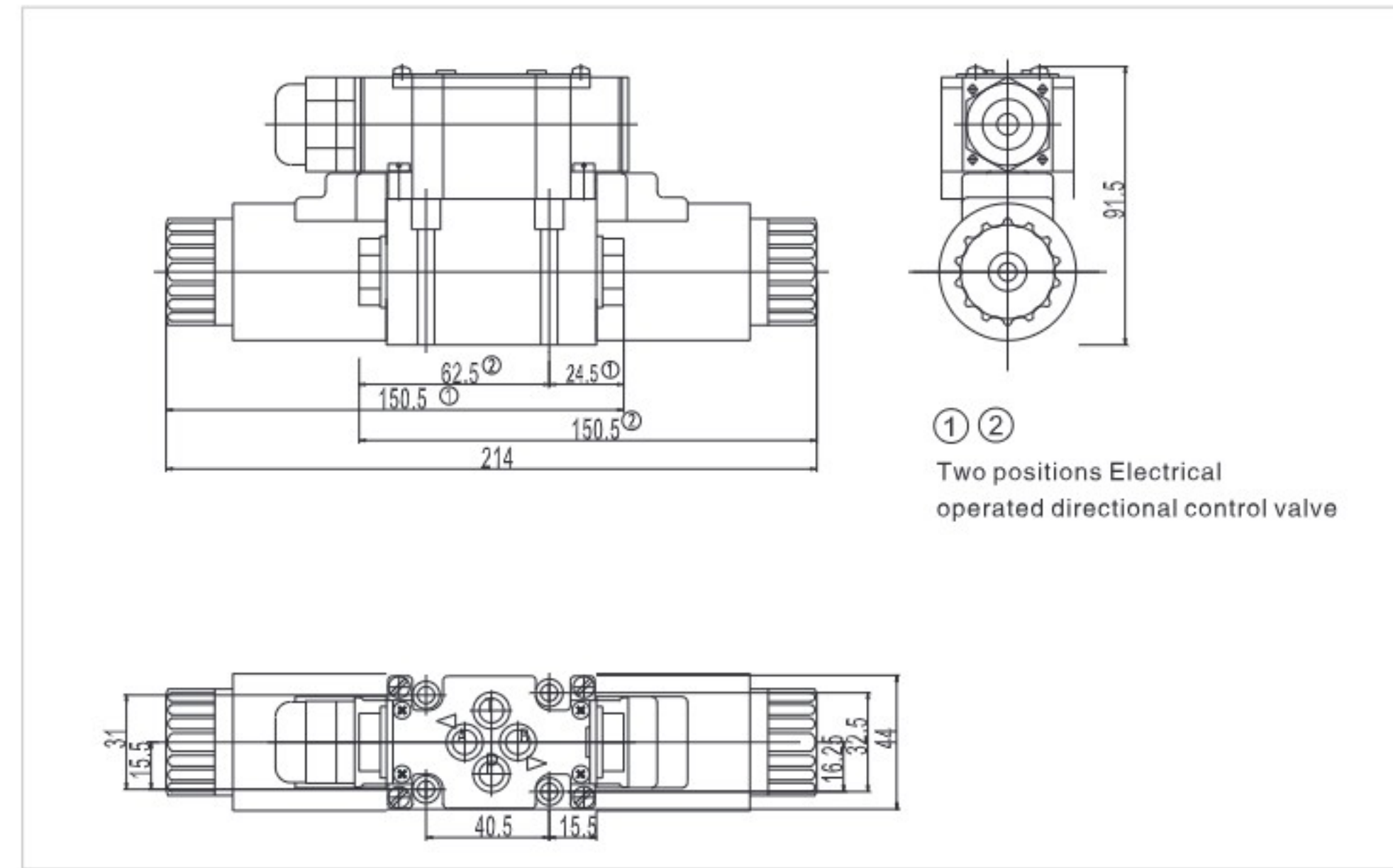

External dimensions ( 02 Direct current wire box type )

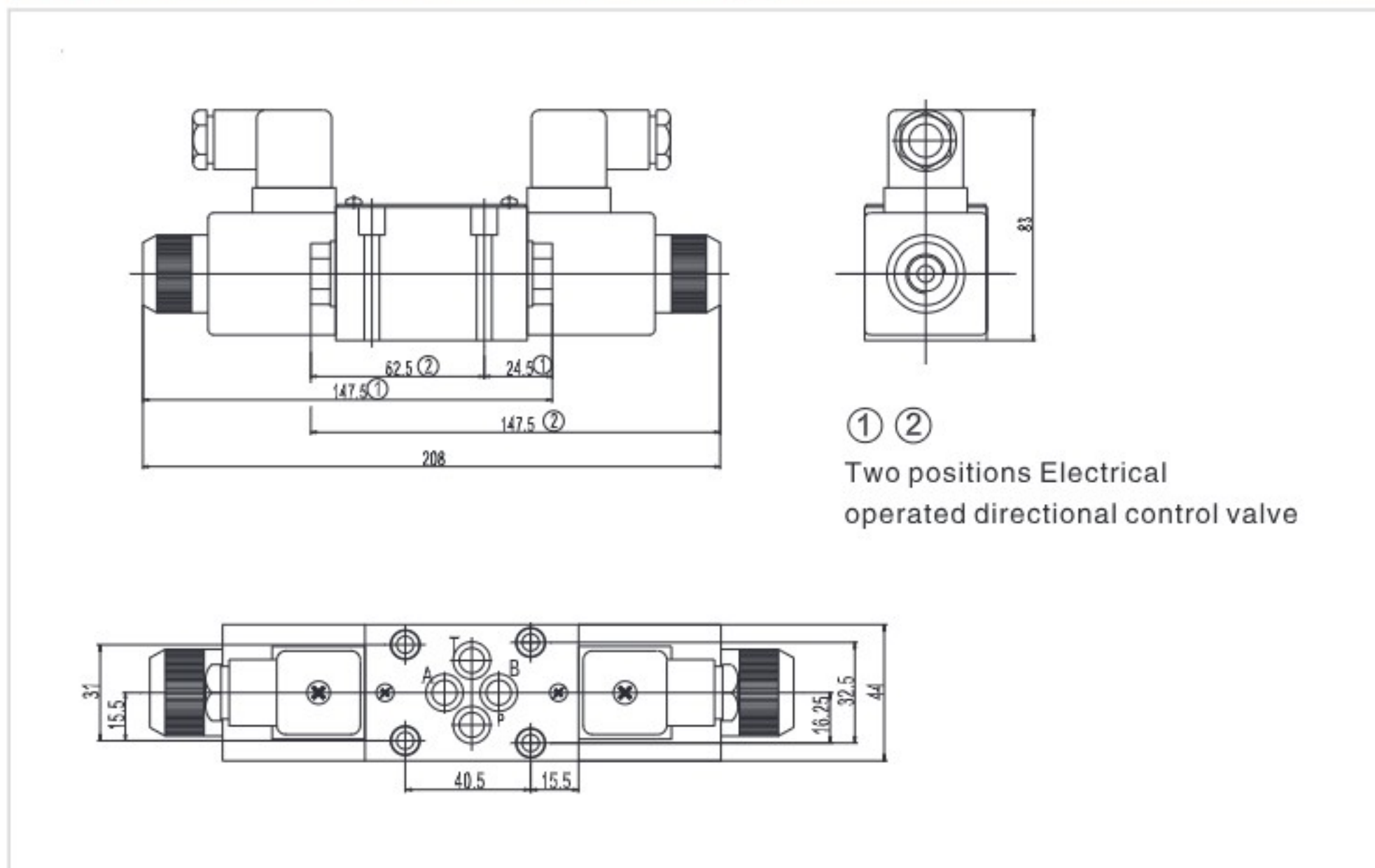

External dimensions ( 02 Alternating current wire box type )

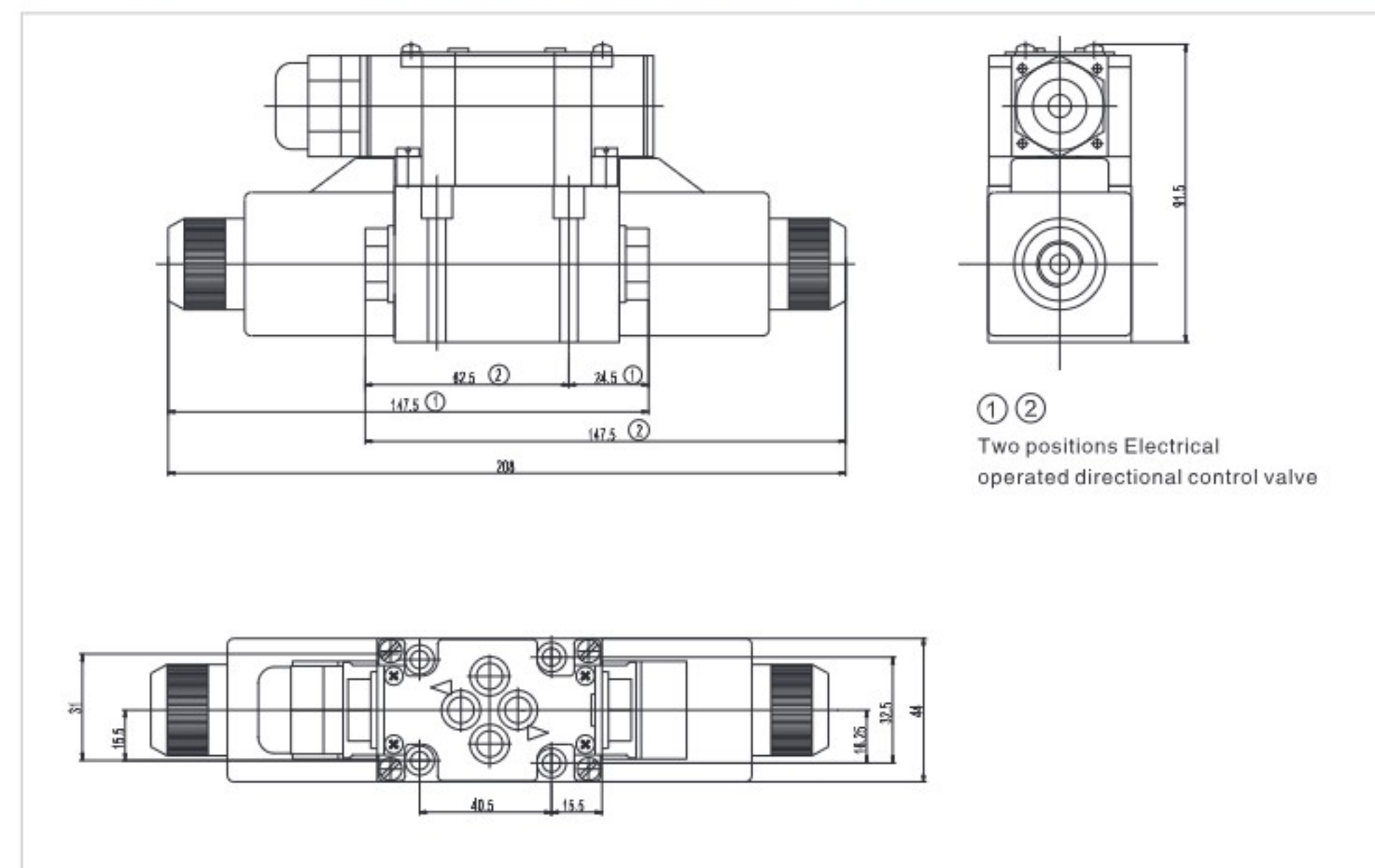



## Electrical Operated Directional Control Valve

### 02 Size of subplate oil port

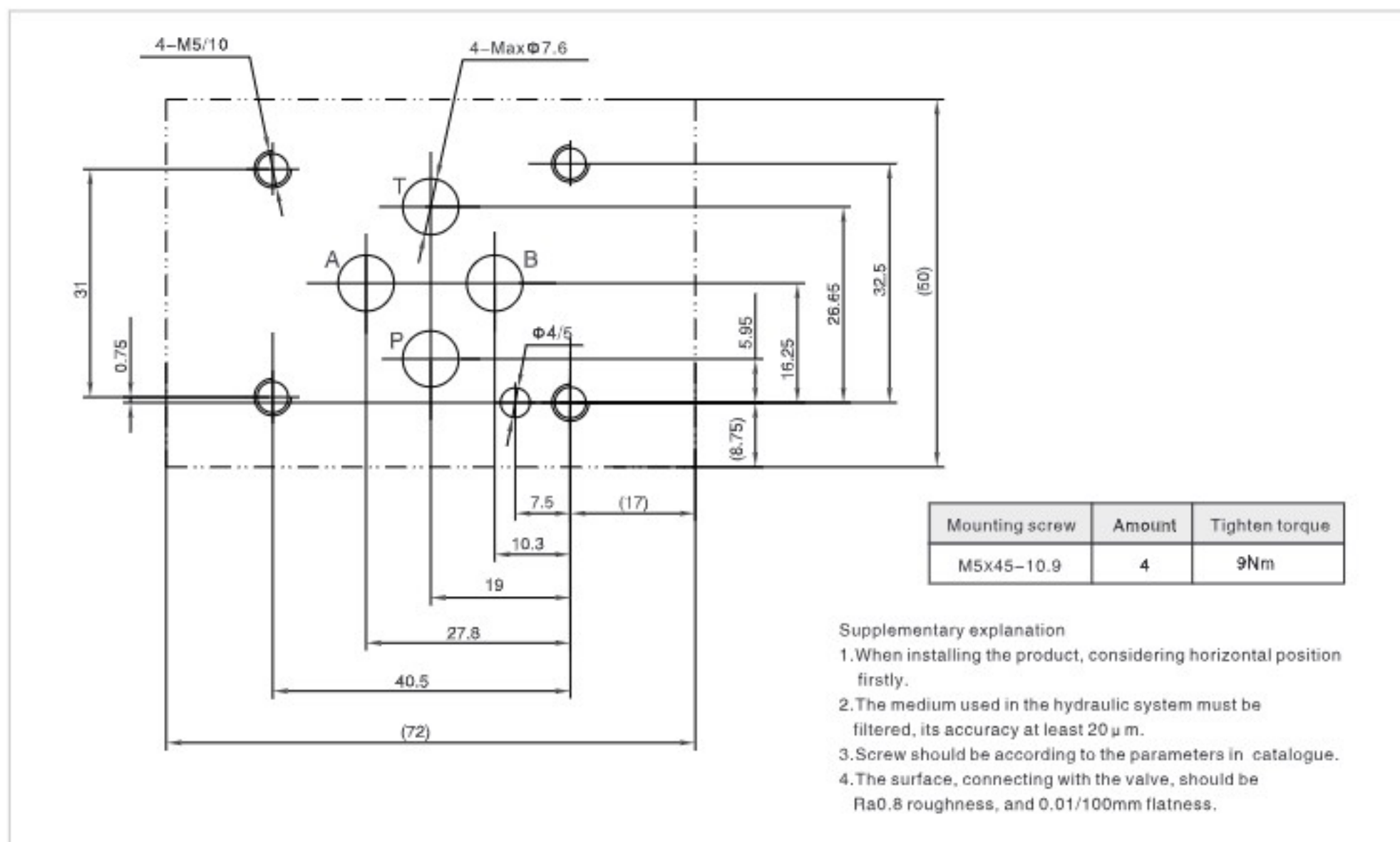

## Electrical Operated Directional Control Valve

### External dimensions ( 03 Alternating current plug type )

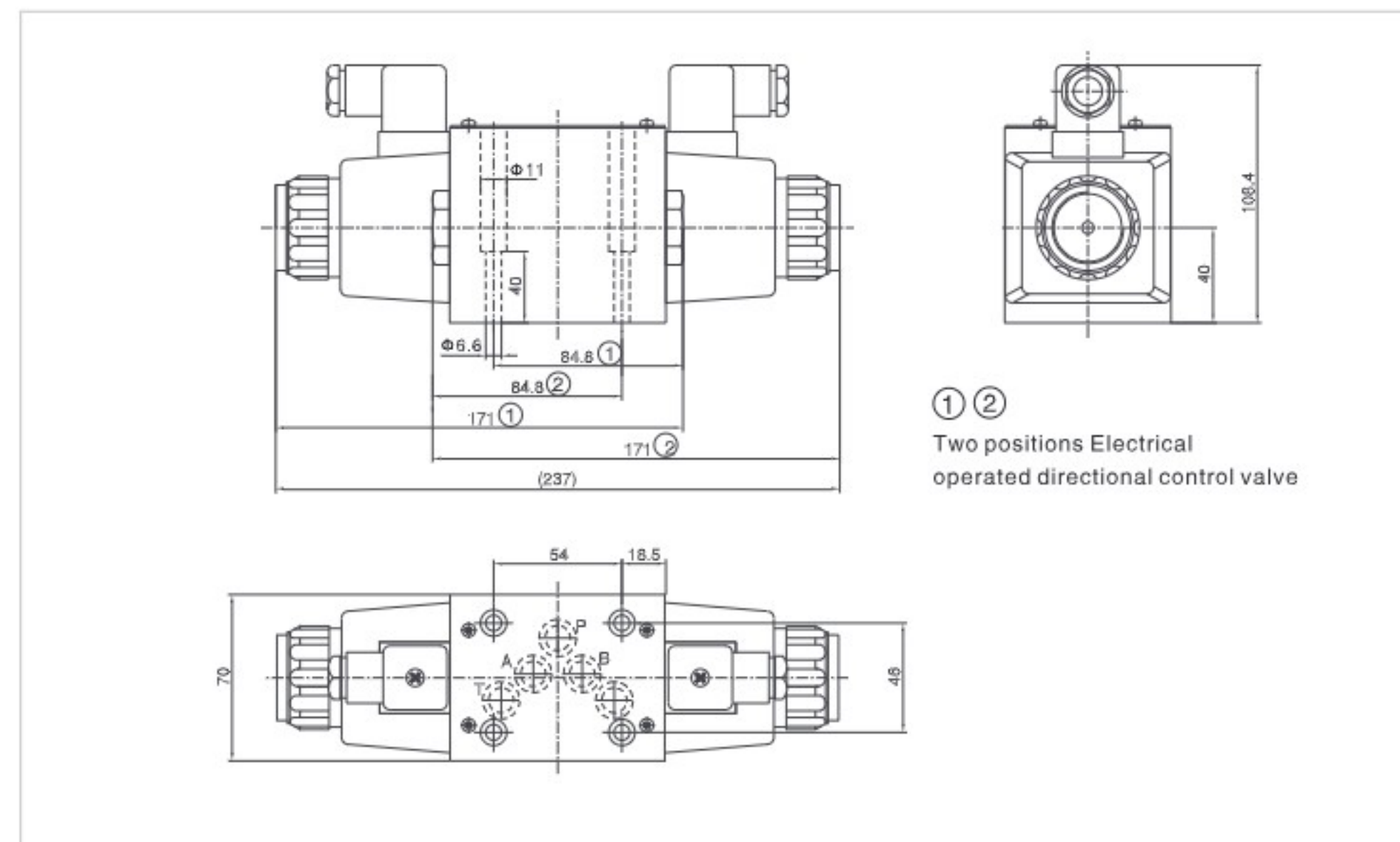

### External dimensions ( 03 Direct current plug type )

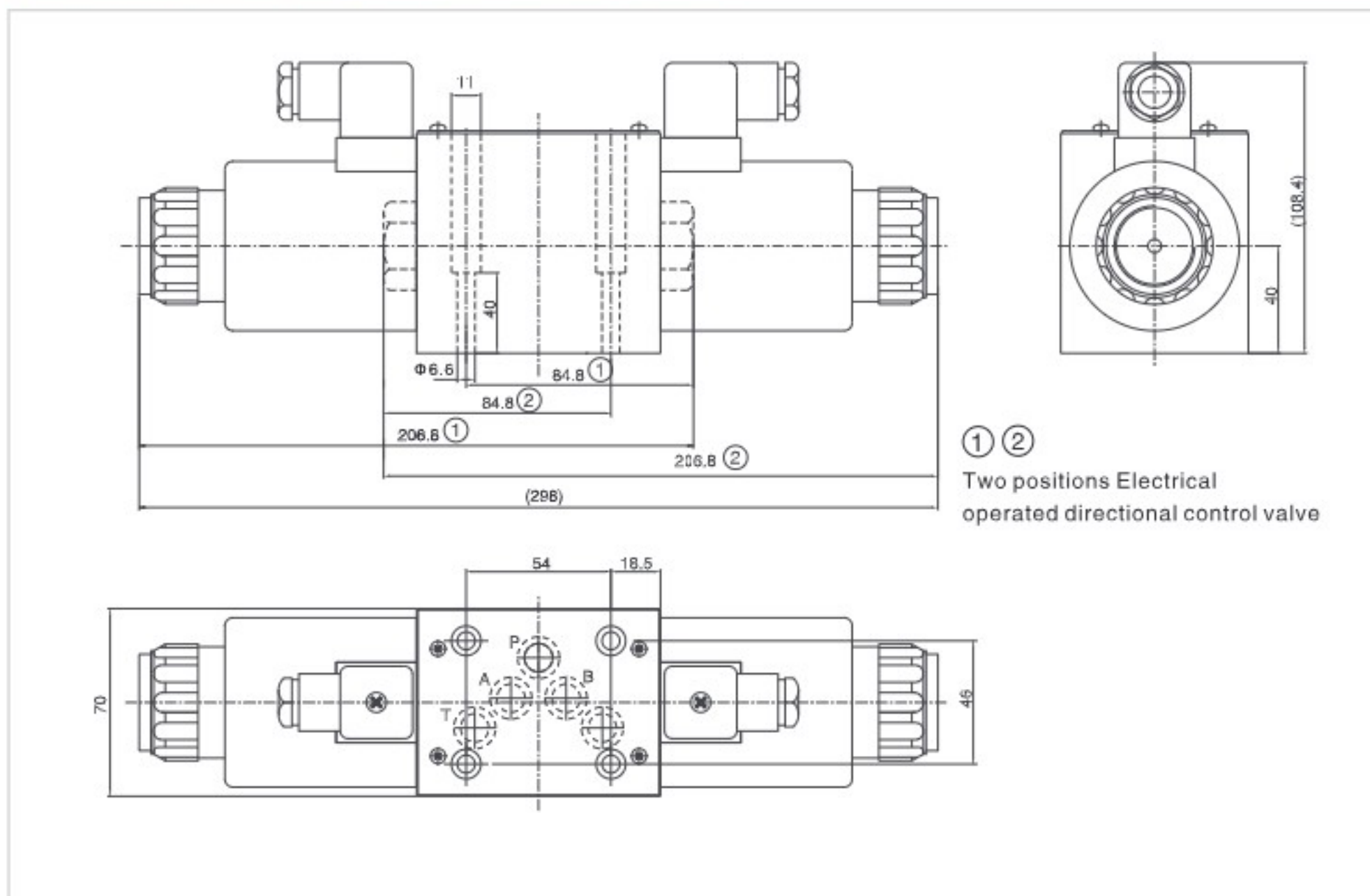

### 03 Size of subplate oil port

