

HYLS04-B30 (Load Shuttle Valve)

Description

A in-line ball-type shuttle valve.

Operation

The valve will allow flow from the higher pressure of port ① or ③ to the port ②. The valve is commonly used to direct oil from the pressure side of a bidirectional hydraulic motor to a pressure-released hydraulic brake.

Specifications

Max. operating pressure:	240 Bar
Flow:	5 L/min
Internal leakage:	5 Drops/min.max.at 240 bar
Temperature:	(-40°C To +120°C) with NBR material seals
Fluids:	Mineral-based fluids with viscosities of 7.4 to 420 cSt.
Cavity:	HY04-B2,see page H.1.1
Body material:	Steel & ductile iron rated to 350 bar

Code symbol , profile and pressure drop vs.flow

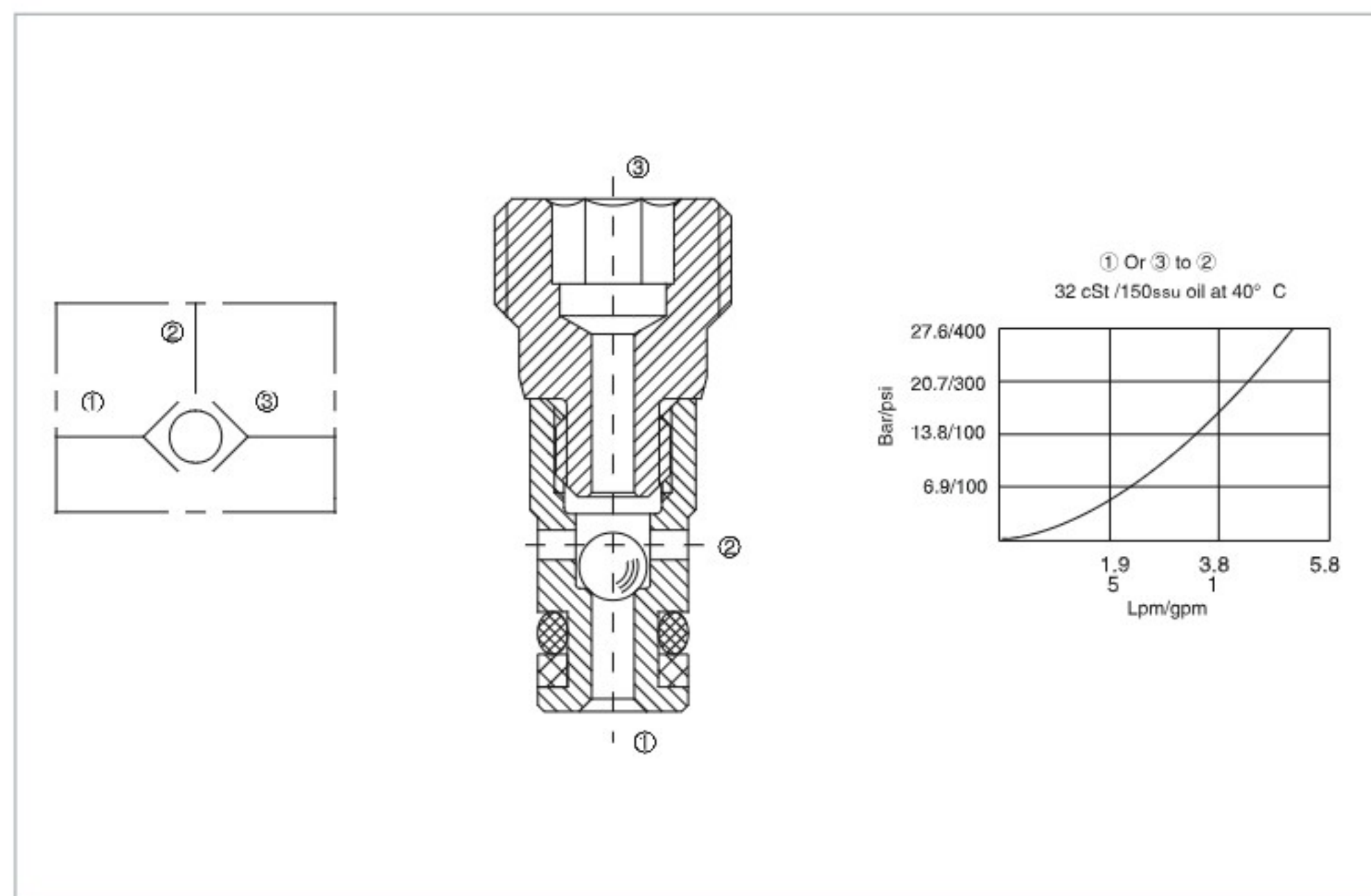

HYLS04-B30 (Load Shuttle Valve)

External dimensions

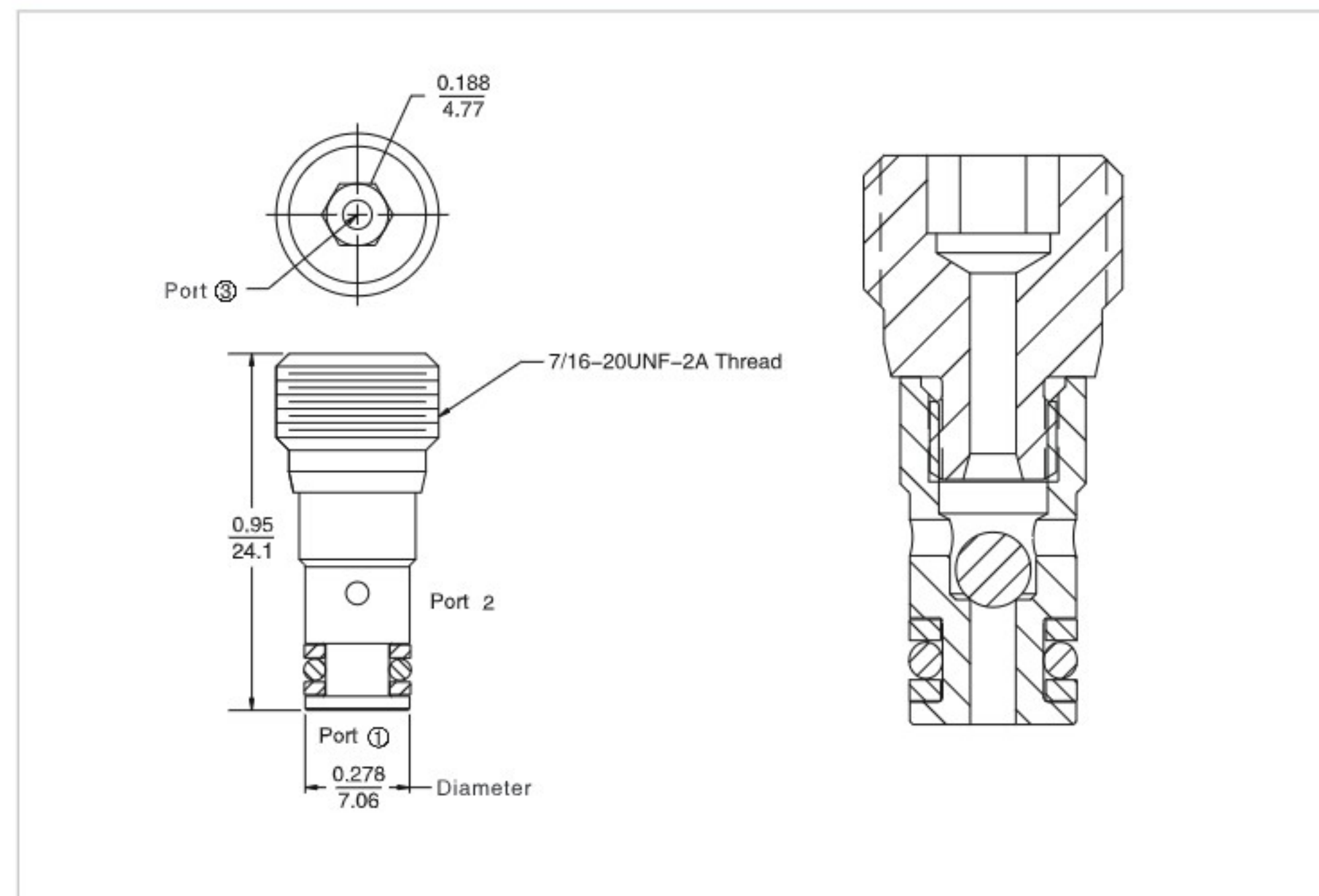

Material science and order model

Cartridge: weight: 0.08 kg (0.17 lb);
Steel, the working face is duratected
Surface zinc-plated;
NBR material sealing and
check ring (standard).

Block: weight :0.27 kg (0.60 lb);
High-strength performance aluminum
alloy with anodic oxidation;
#6061 T6;
Rated pressure up to 240 bar (3500 psi);
See 8.0008.1
Also available with ductile cast iron and
steel material;
Size might be different, please consult factory.

